

Copyright Notice

Copyright (c) 2024 IETF Trust and the persons identified as the document authors. All rights reserved.

This document is subject to BCP 78 and the IETF Trust's Legal Provisions Relating to IETF Documents (<https://trustee.ietf.org/license-info>) in effect on the date of publication of this document. Please review these documents carefully, as they describe your rights and restrictions with respect to this document. Code Components extracted from this document must include Revised BSD License text as described in Section 4.e of the Trust Legal Provisions and are provided without warranty as described in the Revised BSD License.

Table of Contents

1. Introduction	5
1.1. Terminology	5
1.1.1. Requirements Language	6
1.2. Background	7
1.2.1. Segments, Broadcast Domains, and Tenants	7
1.2.2. Inter-BD (Inter-Subnet) IP Traffic	8
1.2.3. EVPN and IP Multicast	8
1.2.4. BDs, MAC-VRFs, and EVPN Service Models	9
1.3. Need for EVPN-Aware Multicast Procedures	9
1.4. Additional Requirements That Must Be Met by the Solution	10
1.5. Model of Operation: Overview	12
1.5.1. Control Plane	12
1.5.2. Data Plane	13
2. Detailed Model of Operation	15
2.1. Supplementary Broadcast Domain	15
2.2. Detecting When a Route is for/from a Particular BD	16
2.3. Use of IRB Interfaces at Ingress PE	18
2.4. Use of IRB Interfaces at an Egress PE	20
2.5. Announcing Interest in (S,G)	20
2.6. Tunneling Frames from Ingress PEs to Egress PEs	21

2.7. Advanced Scenarios	22
3. EVPN-Aware Multicast Solution Control Plane	22
3.1. Supplementary Broadcast Domain (SBD) and Route Targets	22
3.2. Advertising the Tunnels Used for IP Multicast	23
3.2.1. Constructing Routes for the SBD	23
3.2.2. Ingress Replication	24
3.2.3. Assisted Replication	24
3.2.3.1. Automatic SBD Matching	25
3.2.4. BIER	25
3.2.5. Inclusive P2MP Tunnels	26
3.2.5.1. Using the BUM Tunnels as IP Multicast Inclusive Tunnels	26
3.2.5.2. Using Wildcard S-PMSI A-D Routes to Advertise Inclusive Tunnels Specific to IP Multicast	27
3.2.6. Selective Tunnels	28
3.3. Advertising SMET Routes	29
4. Constructing Multicast Forwarding State	31
4.1. Layer 2 Multicast State	31
4.1.1. Constructing the OIF List	32
4.1.2. Data Plane: Applying the OIF List to an (S,G) Frame	32
4.1.2.1. Eligibility of an AC to Receive a Frame	32
4.1.2.2. Applying the OIF List	33
4.2. Layer 3 Forwarding State	34
5. Interworking with Non-OISM EVPN PEs	34
5.1. IPMG Designated Forwarder	36
5.2. Ingress Replication	37
5.2.1. Ingress PE is Non-OISM	38
5.2.2. Ingress PE is OISM	39
5.3. P2MP Tunnels	39

6. Traffic to/from Outside the EVPN Tenant Domain	40
6.1. Layer 3 Interworking via EVPN OISM PEs	40
6.1.1. General Principles	40
6.1.2. Interworking with MVPN	43
6.1.2.1. MVPN Sources with EVPN Receivers	45
6.1.2.1.1. Identifying MVPN Sources	45
6.1.2.1.2. Joining a Flow from an MVPN Source	45
6.1.2.2. EVPN Sources with MVPN Receivers	47
6.1.2.2.1. General Procedures	47
6.1.2.2.2. Any-Source Multicast (ASM) Groups	48
6.1.2.2.3. Source on Multihomed Segment	48
6.1.2.3. Obtaining Optimal Routing of Traffic between MVPN and EVPN	49
6.1.2.4. Selecting the MEG SBD-DR	49
6.1.3. Interworking with Global Table Multicast	50
6.1.4. Interworking with PIM	50
6.1.4.1. Source Inside EVPN Domain	50
6.1.4.2. Source Outside EVPN Domain	51
6.2. Interworking with PIM via an External PIM Router	52
7. Using an EVPN Tenant Domain as an Intermediate (Transit) Network for Multicast Traffic	53
8. IANA Considerations	54
9. Security Considerations	55
10. References	55
10.1. Normative References	55
10.2. Informative References	57
Appendix A. Integrated Routing and Bridging	58
Acknowledgements	62
Authors' Addresses	62

1. Introduction

1.1. Terminology

In this document, we make frequent use of the following terminology:

OISM: Optimized Inter-Subnet Multicast. EVPN PEs that follow the procedures of this document will be known as "OISM" Provider Edges (PEs). EVPN PEs that do not follow the procedures of this document will be known as "non-OISM" PEs.

IP Multicast Packet: An IP packet whose IP Destination Address field is a multicast address that is not a link-local address. (Link-local addresses are IPv4 addresses in the 224/24 range and IPv6 addresses in the FF02/16 range.)

IP Multicast Frame: An Ethernet frame whose payload is an IP multicast packet (as defined above).

(S,G) Multicast Packet: An IP multicast packet whose Source IP Address field contains S and whose IP Destination Address field contains G.

(S,G) Multicast Frame: An IP multicast frame whose payload contains S in its Source IP Address field and G in its IP Destination Address field.

EVI: EVPN Instance. An EVPN instance spanning the PE devices participating in that EVPN.

BD: Broadcast Domain. An emulated Ethernet, such that two systems on the same BD will receive each other's link-local broadcasts.

Note that EVPN supports service models in which a single EVI contains only one BD and service models in which a single EVI contains multiple BDs. Both types of service models are supported by this document. In all models, a given BD belongs to only one EVI.

DF: Designated Forwarder. As defined in [RFC7432], an Ethernet segment may be multihomed (attached to more than one PE). An Ethernet segment may also contain multiple BDs of one or more EVIs. For each such EVI, one of the PEs attached to the segment becomes that EVI's DF for that segment. Since a BD may belong to only one EVI, we can speak unambiguously of the BD's DF for a given segment.

AC: Attachment Circuit. An AC connects the bridging function of an EVPN PE to an Ethernet segment of a particular BD. ACs are not visible at the Layer 3.

If a given Ethernet segment, attached to a given PE, contains n BDs, we say that the PE has n ACs to that segment.

L3 Gateway: An L3 Gateway is a PE that connects an EVPN Tenant Domain to an external multicast domain by performing both the OISM procedures and the Layer 3 multicast procedures of the external domain.

PEG: PIM/EVPN Gateway. An L3 Gateway that connects an EVPN Tenant Domain to an external multicast domain whose Layer 3 multicast procedures are those of PIM [RFC7761].

MEG: MVPN/EVPN Gateway. An L3 Gateway that connects an EVPN Tenant Domain to an external multicast domain whose Layer 3 multicast procedures are those of Multicast VPN (MVPN) [RFC6513] [RFC6514].

IPMG: IP Multicast Gateway. A PE that is used for interworking OISM EVPN PEs with non-OISM EVPN PEs.

DR: Designated Router. A PE that has special responsibilities for handling multicast on a given BD.

FHR: First Hop Router. The FHR is a PIM router [RFC7761] with special responsibilities. It is the first multicast router to see (S,G) packets from source S, and if G is an Any-Source Multicast (ASM) group, the FHR is responsible for sending PIM Register messages to the PIM Rendezvous Point (RP) for group G.

LHR: Last Hop Router. The LHR is a PIM router [RFC7761] with special responsibilities. Generally, it is attached to a LAN, and it determines whether there are any hosts on the LAN that need to receive a given multicast flow. If so, it creates and sends the PIM Join messages that are necessary to receive the flow.

EC: Extended Community. A BGP Extended Communities attribute [RFC4360] [RFC7153] is a BGP path attribute that consists of one or more Extended Communities.

RT: Route Target. A Route Target is a particular kind of BGP Extended Community. A BGP Extended Community consists of a type field, a sub-type field, and a value field. Certain type/sub-type combinations indicate that a particular Extended Community is an RT. RT1 and RT2 are considered to be the same RT if and only if they have the same type, sub-type, and value fields.

C- prefix: In many documents on VPN multicast, the prefix C- appears before any address or wildcard that refers to an address or addresses in a tenant's address space rather than to an address of addresses in the address space of the backbone network. This document omits the C- prefix in many cases where it is clear from the context that the reference is to the tenant's address space.

This document also assumes familiarity with the terminology of [RFC4364], [RFC6514], [RFC7432], [RFC7761], [RFC9136], [RFC9251], and [RFC9572].

1.1.1. Requirements Language

The key words "MUST", "MUST NOT", "REQUIRED", "SHALL", "SHALL NOT", "SHOULD", "SHOULD NOT", "RECOMMENDED", "NOT RECOMMENDED", "MAY", and "OPTIONAL" in this document are to be interpreted as described in BCP 14 [RFC2119] [RFC8174] when, and only when, they appear in all capitals, as shown here.

1.2. Background

Ethernet VPN (EVPN) [RFC7432] provides a Layer 2 VPN (L2VPN) solution, which allows an IP or MPLS backbone provider to offer Ethernet service to a set of customers, known as "tenants".

In this section (as well as in [RFC9135]), we provide some essential background information on EVPN.

1.2.1. Segments, Broadcast Domains, and Tenants

One of the key concepts of EVPN is the Broadcast Domain (BD). A BD is essentially an emulated Ethernet. Each BD belongs to a single tenant. A BD typically consists of multiple Ethernet segments, and each segment may be attached to a different EVPN Provider Edge (EVPN PE) router. EVPN PE routers are often referred to as "Network Virtualization Endpoints (NVEs)". However, this document will use the term "EVPN PE" or, when the context is clear, just "PE".

In this document, the term "segment" is used interchangeably with "Ethernet Segment" or "ES", as defined in [RFC7432].

Attached to each segment are Tenant Systems (TSs). A TS may be any type of system, physical or virtual, host or router, etc., that can attach to an Ethernet.

When two TSs are on the same segment, traffic between them does not pass through an EVPN PE. When two TSs are on different segments of the same BD, traffic between them does pass through an EVPN PE.

When two TSs, say TS1 and TS2, are on the same BD, then the following occurs:

- If TS1 knows the Media Access Control (MAC) address of TS2, TS1 can send unicast Ethernet frames to TS2. TS2 will receive the frames unaltered.
- If TS1 broadcasts an Ethernet frame, TS2 will receive the unaltered frame.
- If TS1 multicasts an Ethernet frame, TS2 will receive the unaltered frame as long as TS2 has been provisioned to receive the Ethernet multicast destination MAC address.

When we say that TS2 receives an unaltered frame from TS1, we mean that the frame still contains TS1's MAC address and that no alteration of the frame's payload (and consequently, no alteration of the payload's IP header) has been made.

EVPN allows a single segment to be attached to multiple PE routers. This is known as "EVPN multihoming". Suppose a given segment is attached to both PE1 and PE2, and suppose PE1 receives a frame from that segment. It may be necessary for PE1 to send the frame over the backbone to PE2. EVPN has procedures to ensure that such a frame cannot be sent back to its originating segment by PE2. This is particularly important for multicast, because a frame arriving at PE1 from a given segment will already have been seen by all the systems on that segment that need to see it. If the frame was sent back to the originating segment by PE2, receivers on that segment would receive the packet twice. Even worse, the frame might be sent back to PE1, which could cause an infinite loop.

1.2.2. Inter-BD (Inter-Subnet) IP Traffic

If a given tenant has multiple BDs, the tenant may wish to allow IP communication among these BDs. Such a set of BDs is known as an "EVPN Tenant Domain" or just a "Tenant Domain".

If tenant systems TS1 and TS2 are not in the same BD, then they do not receive unaltered Ethernet frames from each other. In order for TS1 to send traffic to TS2, TS1 encapsulates an IP datagram inside an Ethernet frame and uses Ethernet to send these frames to an IP router. The router decapsulates the IP datagram, does the IP processing, and re-encapsulates the datagram for Ethernet. The MAC Source Address field now has the MAC address of the router, not of TS1. The TTL field of the IP datagram should be decremented by exactly 1, even if the frame needs to be sent from one PE to another. The structure of the provider's backbone is thus hidden from the tenants.

EVPN accommodates the need for inter-BD communication within a Tenant Domain by providing an integrated L2/L3 service for unicast IP traffic. EVPN's Integrated Routing and Bridging (IRB) functionality is specified in [RFC9135]. Each BD in a Tenant Domain is assumed to be a single IP subnet, and each IP subnet within a given Tenant Domain is assumed to be a single BD. EVPN's IRB functionality allows IP traffic to travel from one BD to another and ensures that proper IP processing (e.g., TTL decrement) is done.

A brief overview of IRB, including the notion of an IRB interface, can be found in [Appendix A](#). As explained there, an IRB interface is a sort of virtual interface connecting an L3 routing instance to a BD. A BD may have multiple Attachment Circuits (ACs) to a given PE, where each AC connects to a different Ethernet segment of the BD. However, these ACs are not visible to the L3 routing function; from the perspective of an L3 routing instance, a PE has just one interface to each BD, viz., the IRB interface for that BD.

In this document, when traffic is routed out of an IRB interface, we say it is sent down the IRB interface to the BD that the IRB is for. In the other direction, traffic is sent up the IRB interface from the BD to the L3 routing instance.

The L3 routing instance depicted in [Appendix A](#) is associated with a single Tenant Domain and may be thought of as IP Virtual Routing and Forwarding (IP-VRF) for that Tenant Domain.

1.2.3. EVPN and IP Multicast

[RFC9135] and [RFC9136] cover inter-subnet (inter-BD) IP unicast forwarding, but they do not cover inter-subnet IP multicast forwarding.

[RFC7432] covers intra-subnet (intra-BD) Ethernet multicast. The intra-subnet Ethernet multicast procedures of [RFC7432] are used for Ethernet broadcast traffic, Ethernet unicast traffic whose Destination MAC Address field contains an unknown address, and Ethernet traffic whose Destination MAC Address field contains an Ethernet multicast MAC address. These three classes of traffic are known collectively as "BUM traffic" (Broadcast, Unknown Unicast, or Multicast traffic), and the procedures for handling BUM traffic are known as "BUM procedures".

[RFC9251] extends the intra-subnet Ethernet multicast procedures by adding procedures that are specific to, and optimized for, the use of IP multicast within a subnet. However, that document does not cover inter-subnet IP multicast.

The purpose of this document is to specify procedures for EVPN that provide optimized IP multicast functionality within an EVPN Tenant Domain. This document also specifies procedures that allow IP multicast packets to be sourced from or destined to systems outside the Tenant Domain. The entire set of procedures are referred to as "Optimized Inter-Subnet Multicast (OISM)" procedures.

In order to support the OISM procedures specified in this document, an EVPN PE **MUST** also support [RFC9135] and [RFC9251]. (However, certain procedures in [RFC9251] are modified when OISM is supported.)

1.2.4. BDs, MAC-VRFs, and EVPN Service Models

[RFC7432] defines the notion of MAC-VRF (MAC Virtual Routing and Forwarding). A MAC-VRF contains one or more bridge tables (see Section 3 of [RFC7432]), each of which represents a single Broadcast Domain.

In the IRB model (outlined in Appendix A), an L3 routing instance has one IRB interface per BD, NOT one per MAC-VRF. This document does not distinguish between a Broadcast Domain and a bridge table; instead, it uses the terms interchangeably (or will use the acronym "BD" to refer to either). The way the BDs are grouped into MAC-VRFs is not relevant to the procedures specified in this document.

Section 6 of [RFC7432] also defines several different EVPN service models:

- In the vlan-based service, each MAC-VRF contains one bridge table, where the bridge table corresponds to a particular Virtual LAN (VLAN) (see Section 3 of [RFC7432]). Thus, each VLAN is treated as a BD.
- In the vlan bundle service, each MAC-VRF contains one bridge table, where the bridge table corresponds to a set of VLANs. Thus, a set of VLANs are treated as constituting a single BD.
- In the vlan-aware bundle service, each MAC-VRF may contain multiple bridge tables, where each bridge table corresponds to one BD. If a MAC-VRF contains several bridge tables, then it corresponds to several BDs.

The procedures in this document are intended to work for all these service models.

1.3. Need for EVPN-Aware Multicast Procedures

Inter-subnet IP multicast among a set of BDs can be achieved, in a non-optimal manner, without any specific EVPN procedures. For instance, if a particular tenant has n BDs among which it wants to send IP multicast traffic, it can simply attach a conventional multicast router to all n BDs. Or more generally, as long as each BD has at least one IP multicast router, and the IP multicast routers communicate multicast control information with each other, conventional IP multicast procedures will work normally, and no special EVPN functionality is needed.

However, that technique does not provide optimal routing for multicast. In conventional multicast routing, for a given multicast flow, there is only one multicast router on each BD that is permitted to send traffic of that flow to the BD. If that BD has receivers for a given flow, but the source of the flow is not on that BD, then the flow must pass through that multicast router. This leads to the hairpinning problem described (for unicast) in [Appendix A](#).

For example, consider an (S,G) flow that is sourced by a TS S and needs to be received by TSs R1 and R2. Suppose S is on a segment of BD1, R1 is on a segment of BD2, but both are attached to PE1. Also suppose that the tenant has a multicast router attached to a segment of BD1 and to a segment of BD2. However, the segments to which that router is attached are both attached to PE2. Then, the flow from S to R would have to follow the path: S-->PE1-->PE2-->tenant multicast router-->PE2-->PE1-->R1. Obviously, the path S-->PE1-->R would be preferred.

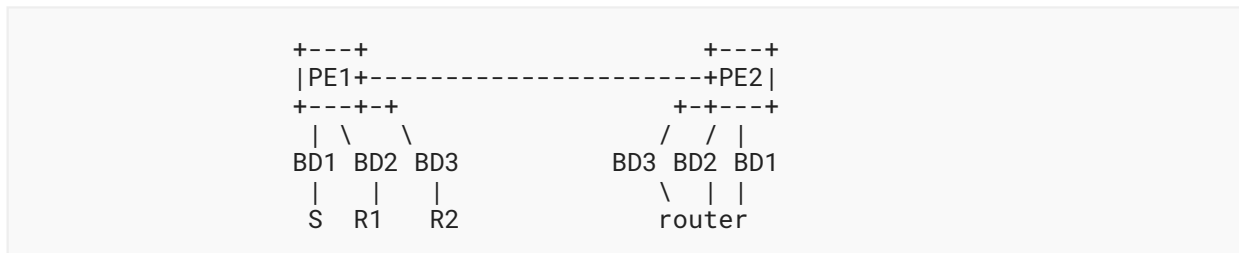

Now suppose that there is a second receiver, R2. R2 is attached to a third BD, BD3. However, it is attached to a segment of BD3 that is attached to PE1. And suppose that the tenant multicast router is attached to a segment of BD3 that attaches to PE2. In this case, the tenant multicast router will make two copies of the packet, one for BD2 and one for BD3. PE2 will send both copies back to PE1. Not only is the routing sub-optimal, but PE2 also sends multiple copies of the same packet to PE1, which is a further sub-optimality.

This is only an example; many more examples of sub-optimal multicast routing can easily be given. To eliminate sub-optimal routing and extra copies, it is necessary to have a multicast solution that is EVPN-aware and that can use its knowledge of the internal structure of a Tenant Domain to ensure that multicast traffic gets routed optimally. The procedures in this document allow us to avoid all such sub-optimality when routing inter-subnet multicast traffic within a Tenant Domain.

1.4. Additional Requirements That Must Be Met by the Solution

In addition to providing optimal routing of multicast flows within a Tenant Domain, the EVPN-aware multicast solution is intended to satisfy the following requirements:

- The solution must integrate well with the procedures specified in [\[RFC9251\]](#). That is, an integrated set of procedures must handle both intra-subnet multicast and inter-subnet multicast.
- With regard to intra-subnet multicast, the solution **MUST** maintain the integrity of the multicast Ethernet service. This means:
 - If a source and a receiver are on the same subnet, the MAC Source Address (SA) of the multicast frame sent by the source will not get rewritten.

- If a source and a receiver are on the same subnet, no IP processing of the Ethernet payload is done. The IP TTL is not decremented, the IPv4 header checksum is not changed, no fragmentation is done, etc.
- On the other hand, if a source and a receiver are on different subnets, the frame received by the receiver will not have the MAC Source Address of the source, as the frame will appear to have come from a multicast router. Also, proper processing of the IP header is done, e.g., TTL decrements by 1, header checksum modification, possible fragmentation, etc.
- If a Tenant Domain contains several BDs, it **MUST** be possible for a multicast flow (even when the multicast group address is an ASM address) to have sources in one of those BDs and receivers in one or more of the other BDs without requiring the presence of any system performing PIM RP functions [RFC7761].
- Sometimes a MAC address used by one TS on a particular BD is also used by another TS on a different BD. Inter-subnet routing of multicast traffic **MUST NOT** make any assumptions about the uniqueness of a MAC address across several BDs.
- If two EVPN PEs attached to the same Tenant Domain both support the OISM procedures, each may receive inter-subnet multicasts from the other, even if the egress PE is not attached to any segment of the BD from which the multicast packets are being sourced. It **MUST NOT** be necessary to provision the egress PE with knowledge of the ingress BD.
- There must be a procedure that allows EVPN PE routers supporting OISM procedures to send/receive multicast traffic to/from EVPN PE routers that support only [RFC7432] but that does not support the OISM procedures or even the procedures of [RFC9135]. However, when interworking with such routers (which we call "non-OISM PE routers"), optimal routing may not be achievable.
- It **MUST** be possible to support scenarios in which multicast flows with sources inside a Tenant Domain have external receivers, i.e., receivers that are outside the domain. It must also be possible to support scenarios where multicast flows with external sources (sources outside the Tenant Domain) have receivers inside the domain.

This presupposes that unicast routes to multicast sources outside the domain can be distributed to EVPN PEs attached to the domain and that unicast routes to multicast sources within the domain can be distributed outside the domain.

Of particular importance are the scenarios in which the external sources and/or receivers are reachable via L3VPN/MVPN or via IP/PIM.

The solution for external interworking **MUST** allow for deployment scenarios in which EVPN does not need to export a host route for every multicast source.

- The solution for external interworking must not presuppose that the same tunneling technology is used within both the EVPN domain and the external domain. For example, MVPN interworking must be possible when MVPN is using MPLS Point-to-Multipoint (P2MP) tunneling and when EVPN is using Ingress Replication (IR) or Virtual eXtensible Local Area Network (VXLAN) tunneling.
- The solution must not be overly dependent on the details of a small set of use cases but must be adaptable to new use cases as they arise. (That is, the solution must be robust.)

1.5. Model of Operation: Overview

1.5.1. Control Plane

In this section, and in the remainder of this document, we assume the reader is familiar with the procedures of IGMP / Multicast Listener Discovery (MLD) (see [RFC3376] and [RFC3810]), by which hosts announce their interest in receiving particular multicast flows.

Consider a Tenant Domain consisting of a set of k BDs: BD1, ..., BD k . To support the OISM procedures, each Tenant Domain must also be associated with a Supplementary Broadcast Domain (SBD). An SBD is treated in the control plane as a real BD, but it does not have any ACs. The SBD has several uses; these will be described later in this document (see Sections 2.1 and 3).

Each PE that attaches to one or more of the BDs in a given Tenant Domain will be provisioned to recognize that those BDs are part of the same Tenant Domain. Note that a given PE does not need to be configured with all the BDs of a given Tenant Domain. In general, a PE will only be attached to a subset of the BDs in a given Tenant Domain and will be configured only with that subset of BDs. However, each PE attached to a given Tenant Domain must be configured with the SBD for that Tenant Domain.

Suppose a particular segment of a particular BD is attached to PE1. [RFC7432] specifies that PE1 must originate an Inclusive Multicast Ethernet Tag (IMET) route for that BD and that the IMET route must be propagated to all other PEs attached to the same BD. If the given segment contains a host that has interest in receiving a particular multicast flow, either an (S,G) flow or a (*,G) flow, PE1 will learn of that interest by participating in the IGMP/MLD snooping procedures, as specified in [RFC4541]. In this case:

- PE1 is interested in receiving the flow;
- the AC attaching the interested host to PE1 is also said to be interested in the flow; and
- the BD containing an AC that is interested in a particular flow is also said to be interested in that flow.

Once PE1 determines that it has an AC that is interested in receiving a particular flow or set of flows, it originates one or more Selective Multicast Ethernet Tag (SMET) routes [RFC9251] to advertise that interest.

Note that each IMET or SMET route is for a particular BD. The notion of a route being for a particular BD is explained in Section 2.2.

When OISM is being supported, the procedures of [RFC9251] are modified as follows:

- The IMET route originated by a particular PE for a particular BD is distributed to all other PEs attached to the Tenant Domain containing that BD, even to those PEs that are not attached to that particular BD.

- The SMET routes originated by a particular PE are originated on a per-Tenant-Domain basis rather than a per-BD basis. That is, the SMET routes are considered to be for the Tenant Domain's SBD rather than any of its ordinary BDs. These SMET routes are distributed to all the PEs attached to the Tenant Domain.

In this way, each PE attached to a given Tenant Domain learns, from the other PEs attached to the same Tenant Domain, the set of flows that are of interest to each of those other PEs.

An OISM PE that is provisioned with several BDs in the same Tenant Domain **MUST** originate an IMET route for each such BD. To indicate its support of [RFC9251], it **SHOULD** attach the EVPN Multicast Flags Extended Community to each such IMET route, but it **MUST** attach the EC to at least one such IMET route.

Suppose PE1 is provisioned with both BD1 and BD2 and considers them to be part of the same Tenant Domain. It is possible that PE1 will receive both an IMET route for BD1 and an IMET route for BD2 from PE2. If either of these IMET routes has the EVPN Multicast Flags Extended Community, PE1 **MUST** assume that PE2 is supporting the procedures of [RFC9251] for ALL BDs in the Tenant Domain.

If a PE supports OISM functionality, it indicates that, by setting the OISM-supported flag in the Multicast Flags Extended Community, it attaches to some or all of its IMET routes. An OISM PE **SHOULD** attach this EC with the OISM-supported flag set to all the IMET routes it originates. However, if PE1 imports IMET routes from PE2, and at least one of PE2's IMET routes indicates that PE2 is an OISM PE, PE1 **MUST** assume that PE2 is following OISM procedures.

1.5.2. Data Plane

Suppose PE1 has an AC to a segment in BD1 and PE1 receives an (S,G) multicast frame from that AC (as defined in Section 1.1).

There may be other ACs of PE1 on which TSs have indicated an interest (via IGMP/MLD) in receiving (S,G) multicast packets. PE1 is responsible for sending the received multicast packet on those ACs. There are two cases to consider:

- **Intra-Subnet Forwarding:** In this case, an AC with interest in (S,G) is connected to a segment that is part of the source BD, BD1. If the segment is not multihomed, or if PE1 is the Designated Forwarder (DF) (see [RFC7432]) for that segment, PE1 sends the multicast frame on that AC without changing the MAC SA. The IP header is not modified at all; in particular, the TTL is not decremented.
- **Inter-Subnet Forwarding:** An AC with interest in (S,G) is connected to a segment of BD2, where BD2 is different than BD1. If PE1 is the DF for that segment (or if the segment is not multihomed), PE1 decapsulates the IP multicast packet, performs any necessary IP processing (including TTL decrement), and then re-encapsulates the packet appropriately for BD2. PE1 then sends the packet on the AC. Note that after re-encapsulation, the MAC SA will be PE1's MAC address on BD2. The IP TTL will have been decremented by 1.

In addition, there may be other PEs that are interested in (S,G) traffic. Suppose PE2 is such a PE. Then, PE1 tunnels a copy of the IP multicast frame (with its original MAC SA and with no alteration of the payload's IP header) to PE2. The tunnel encapsulation contains information that PE2 can use to associate the frame with an apparent source BD. If the actual source BD of the frame is BD1, then:

- If PE2 is attached to BD1, the tunnel encapsulation used to send the frame to PE2 will cause PE2 to identify BD1 as the apparent source BD.
- If PE2 is not attached to BD1, the tunnel encapsulation used to send the frame to PE2 will cause PE2 to identify the SBD as the apparent source BD.

Note that the tunnel encapsulation used for a particular BD will have been advertised in an IMET route or a Selective Provider Multicast Service Interface (S-PMSI) route [RFC9572] for that BD. That route carries a PMSI Tunnel Attribute (PTA), which specifies how packets originating from that BD are encapsulated. This information enables the PE receiving a tunneled packet to identify the apparent source BD as stated above. See [Section 3.2](#) for more details.

When PE2 receives the tunneled frame, it will forward it on any of its ACs that have interest in (S,G).

If PE2 determines from the tunnel encapsulation that the apparent source BD is BD1, then:

- For those ACs that connect PE2 to BD1, the intra-subnet forwarding procedure described above is used, except that it is now PE2, not PE1, carrying out that procedure. Unmodified EVPN procedures from [RFC7432] are used to ensure that a packet originating from a multihomed segment is never sent back to that segment.
- For those ACs that do not connect to BD1, the inter-subnet forwarding procedure described above is used, except that it is now PE2, not PE1, carrying out that procedure.

If the tunnel encapsulation identifies the apparent source BD as the SBD, PE2 applies the inter-subnet forwarding procedures described above to all of its ACs that have interest in the flow.

These procedures ensure that an IP multicast frame travels from its ingress PE to all egress PEs that are interested in receiving it. While in transit, the frame retains its original MAC SA, and the payload of the frame retains its original IP header. Note that in all cases, when an IP multicast packet is sent from one BD to another, these procedures cause its TTL to be decremented by 1.

So far, we have assumed that an IP multicast packet arrives at its ingress PE over an AC that belongs to one of the BDs in a given Tenant Domain. However, it is possible for a packet to arrive at its ingress PE in other ways. Since an EVPN PE supporting IRB has an IP-VRF, it is possible that the IP-VRF will have a VRF interface that is not an IRB interface. For example, there might be a VRF interface that is actually a physical link to an external Ethernet switch, a directly attached host, or a router. When an EVPN PE, say PE1, receives a packet through such means, we will say that the packet has an external source (i.e., a source outside the Tenant Domain). There are also other scenarios in which a multicast packet might have an external source, e.g., it might arrive over an MVPN tunnel from an L3VPN PE. In such cases, we will still refer to PE1 as the "ingress EVPN PE".

When an EVPN PE, say PE1, receives an externally sourced multicast packet, and there are receivers for that packet inside the Tenant Domain, it does the following:

- Suppose PE1 has an AC in BD1 that has interest in (S,G). Then, PE1 encapsulates the packet for BD1, filling in the MAC SA field with PE1's own MAC address on BD1. It sends the resulting frame on the AC.
- Suppose some other EVPN PE, say PE2, has interest in (S,G). PE1 encapsulates the packet for Ethernet, filling in the MAC SA field with PE1's own MAC address on the SBD. PE1 then tunnels the packet to PE2. The tunnel encapsulation will identify the apparent source BD as the SBD. Since the apparent source BD is the SBD, PE2 will know to treat the frame as an inter-subnet multicast.

When IR is used to transmit IP multicast frames from an ingress EVPN PE to a set of egress PEs, then the ingress PE has to send multiple copies of the frame. Each copy is the original Ethernet frame; decapsulation and IP processing take place only at the egress PE.

If a P2MP tree or Bit Index Explicit Replication (BIER) [EVPN-BUM] is used to transmit an IP multicast frame from an ingress PE to a set of egress PEs, then the ingress PE only has to send one copy of the frame to each of its next hops. Again, each egress PE receives the original frame and does any necessary IP processing.

2. Detailed Model of Operation

The model described in [Section 1.5.2](#) can be expressed more precisely using the notion of IRB interface (see [Appendix A](#)). For a given Tenant Domain:

- A given PE has one IRB interface for each BD to which it is attached. This IRB interface connects L3 routing to that BD. When IP multicast packets are sent or received on the IRB interfaces, the semantics of the interface are modified from the semantics described in [Appendix A](#). See [Section 2.3](#) for the details of the modification.
- Each PE also has an IRB interface that connects L3 routing to the SBD. The semantics of this interface is different than the semantics of the IRB interface to the real BDs. See [Section 2.3](#).

In this section, we assume that PIM is not enabled on the IRB interfaces. In general, it is not necessary to enable PIM on the IRB interfaces unless there are PIM routers on one of the Tenant Domain's BDs or there is some other scenario requiring a Tenant Domain's L3 routing instance to become a PIM adjacency of some other system. These cases will be discussed in [Section 7](#).

2.1. Supplementary Broadcast Domain

Suppose a given Tenant Domain contains three BDs (BD1, BD2, and BD3) and two PEs (PE1 and PE2). PE1 attaches to BD1 and BD2, while PE2 attaches to BD2 and BD3.

To carry out the procedures described above, all the PEs attached to the Tenant Domain must be provisioned with the SBD for that Tenant Domain. A RT must be associated with the SBD and provisioned on each of those PEs. We will refer to that RT as the "SBD-RT".

A Tenant Domain is also configured with an IP-VRF [RFC9135], and the IP-VRF is associated with an RT. This RT **MAY** be the same as the SBD-RT.

Suppose an (S,G) multicast frame originating on BD1 has a receiver on BD3. PE1 will transmit the packet to PE2 as a frame, and the encapsulation will identify the frame's source BD as BD1. Since PE2 is not provisioned with BD1, it will treat the packet as if its source BD were the SBD. That is, a packet can be transmitted from BD1 to BD3 even though its ingress PE is not configured for BD3 and/or its egress PE is not configured for BD1.

EVPN supports service models in which a given EVI can contain only one BD. It also supports service models in which a given EVI can contain multiple BDs. No matter which service model is being used for a particular tenant, it is highly **RECOMMENDED** that an EVI containing only the SBD be provisioned for that tenant.

If, for some reason, it is not feasible to provision an EVI that contains only the SBD, it is possible to put the SBD in an EVI that contains other BDs. However, in that case, the SBD-RT **MUST** be different than the RT associated with any other BD. Otherwise, the procedures of this document (as detailed in Sections 2.2 and 3.1) will not produce correct results.

2.2. Detecting When a Route is for/from a Particular BD

In this document, we frequently say that a particular multicast route is "from" or "for" a particular BD or is "related to" or "associated with" a particular BD. These terms are used interchangeably. Subsequent sections of this document explain when various routes must be originated for particular BDs. In this section, we explain how the PE originating a route marks the route to indicate which BD it is for. We also explain how a PE receiving the route determines which BD the route is for.

In EVPN, each BD is assigned a RT. An RT is a BGP Extended Community that can be attached to the BGP routes used by the EVPN control plane. In some EVPN service models, each BD is assigned a unique RT. In other service models, a set of BDs (all in the same EVI) may be assigned the same RT. The RT that is assigned to the SBD is called the "SBD-RT".

In those service models that allow a set of BDs to share a single RT, each BD is assigned a non-zero Tag ID. The Tag ID appears in the Network Layer Reachability Information (NLRI) of many of the BGP routes that are used by the EVPN control plane.

A given route may be for the SBD or an ordinary BD (a BD that is not the SBD). An RT that has been assigned to an ordinary BD will be known as an "ordinary BD-RT".

When constructing an IMET, SMET, S-PMSI, or Leaf [RFC9572] route that is for a given BD, the following rules apply:

- If the route is for an ordinary BD, say BD1, then:
 - the route **MUST** carry the ordinary BD-RT associated with BD1 and
 - the route **MUST NOT** carry any RT that is associated with an ordinary BD other than BD1.

- If the route is for the SBD, the route **MUST** carry the SBD-RT and **MUST NOT** carry any RT that is associated with any other BD.
- As detailed in subsequent sections, under certain circumstances, a route that is for BD1 may carry both the RT of BD1 and also the SBD-RT.

The IMET route for the SBD **MUST** carry a Multicast Flags Extended Community in which an OISM SBD flag is set.

The IMET route for a BD other than the SBD **SHOULD** carry an EVI-RT EC as defined in [RFC9251]. The EC is constructed from the SBD-RT to indicate the BD's corresponding SBD. This allows all PEs to check that they have consistent SBD provisioning and allows an Assisted Replication (AR) replicator to automatically determine a BD's corresponding SBD without any provisioning, as explained in Section 3.2.3.1.

When receiving an IMET, SMET, S-PMSI, or Leaf route, it is necessary for the receiving PE to determine the BD to which the route belongs. This is done by examining the RTs carried by the route, as well as the Tag ID field of the route's NLRI. There are several cases to consider. Some of these cases are error cases that arise when the route has not been properly constructed.

When one of the error cases is detected, the route **MUST** be regarded as a malformed route, and the treat-as-withdraw procedure of [RFC7606] **MUST** be applied. Note that these error cases are only detectable by EVPN procedures at the receiving PE; BGP procedures at intermediate nodes will generally not detect the existence of such error cases and in general **SHOULD NOT** attempt to do so.

Case 1: The receiving PE recognizes more than one of the route's RTs as being an SBD-RT (i.e., the route carries SBD-RTs of more than one Tenant Domain).

This is an error case; the route has not been properly constructed.

Case 2: The receiving PE recognizes one of the route's RTs as being associated with an ordinary BD and recognizes one of the route's other RTs as being associated with a different ordinary BD.

This is an error case; the route has not been properly constructed.

Case 3: The receiving PE recognizes one of the route's RTs as being associated with an ordinary BD in a particular Tenant Domain and recognizes another of the route's RTs as being associated with the SBD of a different Tenant Domain.

This is an error case; the route has not been properly constructed.

Case 4: The receiving PE does not recognize any of the route's RTs as being associated with an ordinary BD in any of its Tenant Domains but does recognize one of the RTs as the SBD-RT of one of its Tenant Domains.

In this case, the receiving PE associates the route with the SBD of that Tenant Domain. This association is made even if the Tag ID field of the route's NLRI is not the Tag ID of the SBD.

This is a normal use case where either (a) the route is for a BD to which the receiving PE is not attached or (b) the route is for the SBD. In either case, the receiving PE associates the route with the SBD.

Case 5: The receiving PE recognizes exactly one of the RTs as an ordinary BD-RT that is associated with one of the PE's EVIs, say EVI-1. The receiving PE also recognizes one of the RTs as being the SBD-RT of the Tenant Domain containing EVI-1.

In this case, the route is associated with the BD in EVI-1 that is identified (in the context of EVI-1) by the Tag ID field of the route's NLRI. (If EVI-1 contains only a single BD, the Tag ID is likely to be zero.)

This is the case where the route is for a BD to which the receiving PE is attached, but the route also carries the SBD-RT. In this case, the receiving PE associates the route with the ordinary BD, not with the SBD.

NB: According to the above rules, the mapping from BD to RT is a many-to-one or one-to-one mapping. A route that an EVPN PE originates for a particular BD carries that BD's RT, and an EVPN PE that receives the route associates it with a BD as described above. However, RTs are not used only to help identify the BD to which a route belongs; they may also be used by BGP to determine the path along which the route is distributed and to determine which PEs receive the route. There may be cases where it is desirable to originate a route for a particular BD but have that route distributed to only some of the EVPN PEs attached to that BD. Or one might want the route distributed to some intermediate set of systems, where it might be modified or replaced before being propagated further. Such situations are outside the scope of this document.

Additionally, there may be situations where it is desirable to exchange routes among two or more different Tenant Domains (EVPN Extranet). Such situations are outside the scope of this document.

2.3. Use of IRB Interfaces at Ingress PE

When an (S,G) multicast frame is received from an AC belonging to a particular BD, say BD1:

1. The frame is sent unchanged to other EVPN PEs that are interested in (S,G) traffic. The encapsulation used to send the frame to the other EVPN PEs depends on the tunnel type being used for multicast transmission. (For our purposes, we consider IR, AR, and BIER to be tunnel types, even though IR, AR, and BIER do not actually use P2MP tunnels.) At the egress PE, the apparent source BD of the frame can be inferred from the tunnel encapsulation. If the egress PE is not attached to the actual source BD, it will infer that the apparent source BD is the SBD.

Note that the inter-PE transmission of a multicast frame among EVPN PEs of the same Tenant Domain does NOT involve the IRB interfaces as long as the multicast frame was received over an AC attached to one of the Tenant Domain's BDs.

2. The frame is also sent up the IRB interface that attaches BD1 to the Tenant Domain's L3 routing instance in this PE. That is, the L3 routing instance, behaving as if it were a multicast router, receives the IP multicast frames that arrive at the PE from its local ACs. The L3 routing instance decapsulates the frame's payload to extract the IP multicast packet, decrements the IP TTL, adjusts the header checksum, and does any other necessary IP processing (e.g., fragmentation).
3. The L3 routing instance keeps track of which BDs have local receivers for (S,G) traffic. (A local receiver is a TS, reachable via a local AC, that has expressed interest in (S,G) traffic.) If the L3 routing instance has an IRB interface to BD2, and it knows that BD2 has a LOCAL receiver interested in (S,G) traffic, it encapsulates the packet in an Ethernet header for BD2, putting its own MAC address in the MAC SA field. Then, it sends the packet down the IRB interface to BD2.

If a packet is sent from the L3 routing instance to a particular BD via the IRB interface (step 3 in the above list), and if the BD in question is NOT the SBD, the packet is sent ONLY to LOCAL ACs of that BD. If the packet needs to go to other PEs, it has already been sent to them in step 1. Note that this is a change in the IRB interface semantics from what is described in [RFC9135] and Figure 3.

If a given locally attached segment is multihomed, existing EVPN procedures ensure that a packet is not sent by a given PE to that segment unless the PE is the DF for that segment. Those procedures also ensure that a packet is never sent by a PE to its segment of origin. Thus, EVPN segment multihoming is fully supported; duplicate delivery to a segment or looping on a segment are thereby prevented without the need for any new procedures to be defined in this document.

What if an IP multicast packet is received from outside the Tenant Domain? For instance, perhaps PE1's IP-VRF for a particular Tenant Domain also has a physical interface leading to an external switch, host, or router and PE1 receives an IP multicast packet or frame on that interface, or perhaps the packet is from an L3VPN or a different EVPN Tenant Domain.

Such a packet is first processed by the L3 routing instance, which decrements TTL and does any other necessary IP processing. Then, the packet is sent into the Tenant Domain by sending it down the IRB interface to the SBD of that Tenant Domain. This requires encapsulating the packet in an Ethernet header. The MAC SA field will contain the PE's own MAC on the SBD.

An IP multicast packet sent by the L3 routing instance down the IRB interface to the SBD is treated as if it had arrived from a local AC, and steps 1-3 are applied. Note that the semantics of sending a packet down the IRB interface to the SBD are thus slightly different than the semantics of sending a packet down other IRB interfaces. IP multicast packets sent down the SBD's IRB interface may be distributed to other PEs, but IP multicast packets sent down other IRB interfaces are distributed only to local ACs.

If a PE sends a link-local multicast packet down the SBD IRB interface, that packet will be distributed (as an Ethernet frame) to other PEs of the Tenant Domain but will not appear on any of the actual BDs.

2.4. Use of IRB Interfaces at an Egress PE

Suppose an egress EVPN PE receives an (S,G) multicast frame from the frame's ingress EVPN PE. As described above, the packet will arrive as an Ethernet frame over a tunnel from the ingress PE, and the tunnel encapsulation will identify the source BD of the Ethernet frame.

We define the notion of the frame's apparent source BD as follows. If the egress PE is attached to the actual source BD, the actual source BD is the apparent source BD. If the egress PE is not attached to the actual source BD, the SBD is the apparent source BD.

The egress PE now takes the following steps:

1. If the egress PE has ACs belonging to the apparent source BD of the frame, it sends the frame unchanged to any ACs of that BD that have interest in (S,G) packets. The MAC SA of the frame is not modified, and the IP header of the frame's payload is not modified in any way.
2. The frame is also sent to the L3 routing instance by being sent up the IRB interface that attaches the L3 routing instance to the apparent source BD. Steps 2 and 3 listed in [Section 2.3](#) are then applied.

2.5. Announcing Interest in (S,G)

[\[RFC9251\]](#) defines procedures used by an egress PE to announce its interest in a multicast flow or set of flows. If an egress PE determines it has LOCAL receivers in a particular BD, say BD1, that are interested in a particular set of flows, it originates one or more SMET routes for BD1. Each SMET route specifies a particular (S,G) or (*,G) flow. By originating a SMET route for BD1, a PE is announcing "I have receivers for (S,G) or (*,G) in BD1". Such a SMET route carries the RT for BD1, ensuring that it will be distributed to all PEs that are attached to BD1.

The OISM procedures for originating SMET routes differ slightly from those in [\[RFC9251\]](#). In most cases, the SMET routes are considered to be for the SBD rather than the BD containing local receivers. These SMET routes carry the SBD-RT and do not carry any ordinary BD-RT. Details on the processing of SMET routes can be found in [Section 3.3](#).

Since the SMET routes carry the SBD-RT, every ingress PE attached to a particular Tenant Domain will learn of all other PEs (attached to the same Tenant Domain) that have interest in a particular set of flows. Note that a PE that receives a given SMET route does not necessarily have any BDs (other than the SBD) in common with the PE that originates that SMET route.

If all the sources and receivers for a given (*,G) are in the Tenant Domain, inter-subnet ASM traffic will be properly routed without requiring any RPs, shared trees, or other complex aspects of multicast routing infrastructure. Suppose, for example, that:

- PE1 has a local receiver, on BD1, for (*,G) and
- PE2 has a local source, on BD2, for (*,G).

PE1 will originate a SMET(*,G) route for the SBD, and PE2 will receive that route, even if PE2 is not attached to BD1. PE2 will thus know to forward (S,G) traffic to PE1. PE1 does not need to do any source discovery. (This does assume that source S does not send the same (S,G) datagram on two different BDs and that the Tenant Domain does not contain two or more sources with the same IP address S. The use of multicast sources that have IP anycast addresses is outside the scope of this document.)

If some PE attached to the Tenant Domain does not support [RFC9251], it will be assumed to be interested in all flows. Whether a particular remote PE supports [RFC9251] or not is determined by the presence of the Multicast Flags Extended Community in its IMET route; this is specified in [RFC9251].

2.6. Tunneling Frames from Ingress PEs to Egress PEs

[RFC7432] specifies the procedures for setting up and using BUM tunnels. A BUM tunnel is a tunnel used to carry traffic on a particular BD if that traffic is (a) broadcast traffic, (b) unicast traffic with an unknown Destination MAC Address, or (c) Ethernet multicast traffic.

This document allows the BUM tunnels to be used as the default tunnels for transmitting IP multicast frames. It also allows a separate set of tunnels to be used, instead of the BUM tunnels, as the default tunnels for carrying IP multicast frames. Let's call these "IP multicast tunnels".

When the tunneling is done via IR or via BIER, this difference is of no significance. However, when P2MP tunnels are used, there is a significant advantage to having separate IP multicast tunnels.

It is desirable for an ingress PE to transmit a copy of a given (S,G) multicast frame on only one P2MP tunnel. All egress PEs interested in (S,G) packets then have to join that tunnel. If the source BD and PE for an (S,G) frame are BD1 and PE1, respectively, and if PE2 has receivers on BD2 for (S,G), then PE2 must join the P2MP Label Switched Path (LSP) on which PE1 transmits the (S,G) frame. PE2 must join this P2MP LSP even if PE2 is not attached to the source BD, BD1. If PE1 was transmitting the multicast frame on its BD1 BUM tunnel, then PE2 would have to join the BD1 BUM tunnel, even though PE2 has no BD1 Attachment Circuits. This would cause PE2 to pull all the BUM traffic from BD1, most of which it would just have to discard. Thus, it is **RECOMMENDED** that the default IP multicast tunnels be distinct from the BUM tunnels.

Notwithstanding the above, link-local IP multicast traffic **MUST** always be carried on the BUM tunnels and **ONLY** on the BUM tunnels. Link-local IP multicast traffic consists of IPv4 traffic with a destination address prefix of 224/24 and IPv6 traffic with a destination address prefix of FF02/16. In this document, the terms "IP multicast packet" and "IP multicast frame" are defined in [Section 1.1](#) so as to exclude link-local traffic.

Note that it is also possible to use selective tunnels to carry particular multicast flows (see [Section 3.2](#)). When an (S,G) frame is transmitted on a selective tunnel, it is not transmitted on the BUM tunnel or on the default IP multicast tunnel.

2.7. Advanced Scenarios

There are some deployment scenarios that require special procedures:

1. Some multicast sources or receivers are attached to PEs that support [RFC7432] but do not support this document or [RFC9135]. To interoperate with these non-OISM PEs, it is necessary to have one or more gateway PEs that interface the tunnels discussed in this document with the BUM tunnels of the legacy PEs. This is discussed in [Section 5](#).
2. Sometimes multicast traffic originates from outside the EVPN domain or needs to be sent outside the EVPN domain. This is discussed in [Section 6](#). An important special case of this, integration with MVPN, is discussed in [Section 6.1.2](#).
3. In some scenarios, one or more of the tenant systems is a PIM router, and the Tenant Domain is used as a transit network that is part of a larger multicast domain. This is discussed in [Section 7](#).

3. EVPN-Aware Multicast Solution Control Plane

3.1. Supplementary Broadcast Domain (SBD) and Route Targets

As discussed in [Section 2.1](#), every Tenant Domain is associated with a single SBD. Recall that a Tenant Domain is defined to be a set of BDs that can freely send and receive IP multicast traffic to/from each other. If an EVPN PE has one or more ACs in a BD of a particular Tenant Domain, and if the EVPN PE supports the procedures of this document, that EVPN PE **MUST** be provisioned with the SBD of that Tenant Domain.

At each EVPN PE attached to a given Tenant Domain, there is an IRB interface leading from the L3 routing instance of that Tenant Domain to the SBD. However, the SBD has no ACs.

Each SBD is provisioned with a RT. All the EVPN PEs supporting a given SBD are provisioned with that RT as an import RT. That RT **MUST NOT** be the same as the RT associated with any other BD.

We will use the term "SBD-RT" to denote the RT that has been assigned to the SBD. Routes carrying this RT will be propagated to all EVPN PEs in the same Tenant Domain as the originator.

[Section 2.2](#) specifies the rules by which an EVPN PE that receives a route determines whether a received route belongs to a particular ordinary BD or SBD.

[Section 2.2](#) also specifies additional rules that must be followed when constructing routes that belong to a particular BD, including the SBD.

The SBD **SHOULD** be in an EVI of its own. Even if the SBD is not in an EVI of its own, the SBD-RT **MUST** be different than the RT associated with any other BD. This restriction is necessary in order for the rules of [Sections 2.2](#) and [3.1](#) to work correctly.

Note that an SBD, just like any other BD, is associated on each EVPN PE with a MAC-VRF. Per [RFC7432], each MAC-VRF is associated with a Route Distinguisher (RD). When constructing a route that is for an SBD, an EVPN PE will place the RD of the associated MAC-VRF in the Route Distinguisher field of the NLRI. (If the Tenant Domain has several MAC-VRFs on a given PE, the EVPN PE has a choice of which RD to use.)

If AR [RFC9574] is used, each AR-REPLICATOR for a given Tenant Domain must be provisioned with the SBD of that Tenant Domain, even if the AR-REPLICATOR does not have any L3 routing instances.

3.2. Advertising the Tunnels Used for IP Multicast

The procedures used for advertising the tunnels that carry IP multicast traffic depend upon the type of tunnel being used. If the tunnel type is neither IR, AR, nor BIER, there are procedures for advertising both inclusive tunnels and selective tunnels.

When IR, AR, or BIER are used to transmit IP multicast packets across the core, there are no P2MP tunnels. Once an ingress EVPN PE determines the set of egress EVPN PEs for a given flow, the IMET routes contain all the information needed to transport packets of that flow to the egress PEs.

If AR is used, the ingress EVPN PE is also an AR-LEAF, and the IMET route coming from the selected AR-REPLICATOR contains the information needed. The AR-REPLICATOR will behave as an ingress EVPN PE when sending a flow to the egress EVPN PEs.

If the tunneling technique requires P2MP tunnels to be set up (e.g., RSVP-TE P2MP, Multipoint LDP (mLDP), or PIM), some of the tunnels may be selective tunnels and some may be inclusive tunnels.

Selective P2MP tunnels are always advertised by the ingress PE using S-PMSI Auto-Discovery (A-D) routes [RFC9572].

For inclusive tunnels, there is a choice between using a BD's ordinary BUM tunnel as the default inclusive tunnel for carrying IP multicast traffic or using a separate IP multicast tunnel as the default inclusive tunnel for carrying IP multicast. In the former case, the inclusive tunnel is advertised in an IMET route. In the latter case, the inclusive tunnel is advertised in a (C-*,C-*) S-PMSI A-D route [RFC9572]. Details may be found in subsequent sections.

3.2.1. Constructing Routes for the SBD

There are situations in which an EVPN PE needs to originate IMET, SMET, and/or S-PMSI routes for the SBD. Throughout this document, we will refer to such routes respectively as "SBD-IMET routes", "SBD-SMET routes", and "SBD-SPMSI routes". Subsequent sections detail the conditions under which these routes need to be originated.

When an EVPN PE needs to originate an SBD-IMET, SBD-SMET, or SBD-SPMSI route, it constructs the route as follows:

- The RD field of the route's NLRI is set to the RD of the MAC-VRF that is associated with the SBD.
- The SBD-RT is attached to the route.
- The Tag ID field of the route's NLRI is set to the Tag ID that has been assigned to the SBD. This is most likely 0 if a VLAN-based or VLAN-bundle service is being used but non-zero if a VLAN-aware bundle service is being used.

3.2.2. Ingress Replication

When IR is used to transport IP multicast frames of a given Tenant Domain, each EVPN PE attached to that Tenant Domain **MUST** originate an SBD-IMET route (see [Section 3.2.1](#)).

The SBD-IMET route **MUST** carry a PTA, and the MPLS Label field of the PTA **MUST** specify a downstream-assigned MPLS label that maps uniquely (in the context of the originating EVPN PE) to the SBD.

Following the procedures of [\[RFC7432\]](#), an EVPN PE **MUST** also originate an IMET route for each BD to which it is attached. Each of these IMET routes carries a PTA specifying a downstream-assigned label that maps uniquely, in the context of the originating EVPN PE, to the BD in question. These IMET routes need not carry the SBD-RT.

When an ingress EVPN PE needs to use IR to send an IP multicast frame from a particular source BD to an egress EVPN PE, the ingress PE determines whether or not the egress PE has originated an IMET route for that BD. If so, that IMET route contains the MPLS label that the egress PE has assigned to the source BD. The ingress PE uses that label when transmitting the packet to the egress PE. Otherwise, the ingress PE uses the label that the egress PE has assigned to the SBD (in the SBD-IMET route originated by the egress).

Note that the set of IMET routes originated by a given egress PE, and installed by a given ingress PE, may change over time. If the egress PE withdraws its IMET route for the source BD, the ingress PE **MUST** stop using the label carried in that IMET route and instead **MUST** use the label carried in the SBD-IMET route from that egress PE. Implementors must also take into account that an IMET route from a particular PE for a particular BD may arrive after that PE's SBD-IMET route.

3.2.3. Assisted Replication

When AR is used to transport IP multicast frames of a given Tenant Domain, each EVPN PE (including the AR-REPLICATOR) attached to the Tenant Domain **MUST** originate an SBD-IMET route (see [Section 3.2.1](#)).

An AR-REPLICATOR attached to a given Tenant Domain is considered to be an EVPN PE of that Tenant Domain. It is attached to all the BDs in the Tenant Domain, but it does not necessarily have L3 routing instances.

As with IR, the SBD-IMET route carries a PTA where the MPLS Label field specifies the downstream-assigned MPLS label that identifies the SBD. However, the AR-REPLICATOR and AR-LEAF EVPN PEs will set the PTA's flags differently, as per [RFC9574].

In addition, each EVPN PE originates an IMET route for each BD to which it is attached. As in the case of IR, these routes carry the downstream-assigned MPLS labels that identify the BDs and do not carry the SBD-RT.

When an ingress EVPN PE, acting as AR-LEAF, needs to send an IP multicast frame from a particular source BD to an egress EVPN PE, the ingress PE determines whether or not there is any AR-REPLICATOR that originated an IMET route for that BD. After the AR-REPLICATOR selection (if there are more than one), the AR-LEAF uses the label contained in the IMET route of the AR-REPLICATOR when transmitting packets to it. The AR-REPLICATOR receives the packet and, based on the procedures specified in [RFC9574] and in Section 3.2.2 of this document, transmits the packets to the egress EVPN PEs using the labels contained in the received IMET routes for either the source BD or the SBD.

If an ingress AR-LEAF for a given BD has not received any IMET route for that BD from an AR-REPLICATOR, the ingress AR-LEAF follows the procedures in Section 3.2.2.

3.2.3.1. Automatic SBD Matching

Each PE needs to know a BD's corresponding SBD. Configuring that information in each BD is one way, but it requires repetitive configuration and consistency checking (to make sure that all the BDs of the same tenant are configured with the same SBD). A better way is to configure the SBD info in the L3 routing instance so that all related BDs will derive the SBD information.

An AR-REPLICATOR also needs to know the same information, though it does not necessarily have an L3 routing instance. However, from the EVI-RT EC in a BD's IMET route, an AR-REPLICATOR can derive the corresponding SBD of that BD without any configuration.

3.2.4. BIER

When BIER is used to transport multicast packets of a given Tenant Domain, and a given EVPN PE attached to that Tenant Domain is a possible ingress EVPN PE for traffic originating outside that Tenant Domain, the given EVPN PE **MUST** originate an SBD-IMET route (see Section 3.2.1).

In addition, IMET routes that are originated for other BDs in the Tenant Domain **MUST** carry the SBD-RT.

Each IMET route (including but not limited to the SBD-IMET route) **MUST** carry a PTA. The MPLS Label field of the PTA **MUST** specify an upstream-assigned MPLS label that maps uniquely (in the context of the originating EVPN PE) to the BD for which the route is originated.

Suppose an ingress EVPN PE, say PE1, needs to use BIER to tunnel an IP multicast frame to a set of egress EVPN PEs. And suppose the frame's source BD is BD1. The frame is encapsulated as follows:

- A four-octet MPLS label stack entry [RFC3032] is prepended to the frame. The Label field is set to the upstream-assigned label that PE1 has assigned to BD1.
- The resulting MPLS packet is then encapsulated in a BIER encapsulation [RFC8296] [EVPN-BUM]. The BIER BitString is set to identify the egress EVPN PEs. The BIER Proto field is set to the value for "MPLS packet with an upstream-assigned label at top of the stack".

Note: It is possible that the packet being tunneled from PE1 originated outside the Tenant Domain. In this case, the actual source BD, BD1, is considered to be the SBD, and the upstream-assigned label it carries will be the label that PE1 assigned to the SBD and advertised in its SBD-IMET route.

Suppose an egress PE, say PE2, receives such a BIER packet. The BFIR-id field of the BIER header allows PE2 to determine that the ingress PE is PE1. There are then two cases to consider:

1. PE2 has received and installed an IMET route for BD1 from PE1.

In this case, the BIER packet will be carrying the upstream-assigned label that is specified in the PTA of that IMET route. This enables PE2 to determine the apparent source BD (as defined in Section 2.4).

2. PE2 has not received and installed an IMET route for BD1 from PE1.

In this case, PE2 will not recognize the upstream-assigned label carried in the BIER packet. PE2 **MUST** discard the packet.

Further details on the use of BIER to support EVPN can be found in [EVPN-BUM].

3.2.5. Inclusive P2MP Tunnels

3.2.5.1. Using the BUM Tunnels as IP Multicast Inclusive Tunnels

The procedures in this section apply only when:

- a) it is desired to use the BUM tunnels to carry IP multicast traffic across the backbone and
- b) the BUM tunnels are P2MP tunnels (i.e., neither IR, AR, nor BIER are being used to transport the BUM traffic).

In this case, an IP multicast frame (whether inter-subnet or intra-subnet) will be carried across the backbone in the BUM tunnel belonging to its source BD. Each EVPN PE attached to a given Tenant Domain needs to join the BUM tunnels for every BD in the Tenant Domain, even those BDs to which the EVPN PE is not locally attached. This ensures that an IP multicast packet from any source BD can reach all PEs attached to the Tenant Domain.

Note that this will cause all the BUM traffic from a given BD in a Tenant Domain to be sent to all PEs that attach to that Tenant Domain, even the PEs that don't attach to the given BD. To avoid this, it is **RECOMMENDED** that the BUM tunnels not be used as IP multicast inclusive tunnels and that the procedures of [Section 3.2.5.2](#) be used instead.

If a PE is a possible ingress EVPN PE for traffic originating outside the Tenant Domain, the PE **MUST** originate an SBD-IMET route (see [Section 3.2.1](#)). This route **MUST** carry a PTA specifying the P2MP tunnel used for transmitting IP multicast packets that originate outside the Tenant Domain. All EVPN PEs of the Tenant Domain **MUST** join the tunnel specified in the PTA of an SBD-IMET route:

- If the tunnel is an RSVP-TE P2MP tunnel, the originator of the route **MUST** use RSVP-TE P2MP procedures to add each PE of the Tenant Domain to the tunnel, even PEs that have not originated an SBD-IMET route.
- If the tunnel is an mLDP or PIM tunnel, each PE importing the SBD-IMET route **MUST** add itself to the tunnel, using mLDP or PIM procedures, respectively.

Whether or not a PE originates an SBD-IMET route, it will of course originate an IMET route for each BD to which it is attached. Each of these IMET routes **MUST** carry the SBD-RT, as well as the RT for the BD to which it belongs.

If a received IMET route is not the SBD-IMET route, it will also be carrying the RT for its source BD. The route's NLRI will carry the Tag ID for the source BD. From the RT and the Tag ID, any PE receiving the route can determine the route's source BD.

If the MPLS Label field of the PTA contains zero, the specified P2MP tunnel is used only to carry frames of a single source BD.

If the MPLS Label field of the PTA does not contain zero, it **MUST** contain an upstream-assigned MPLS label that maps uniquely (in the context of the originating EVPN PE) to the source BD (or in the case of an SBD-IMET route, to the SBD). The tunnel may then be used to carry frames of multiple source BDs. The apparent source BD of a particular packet is inferred from the label carried by the packet.

IP multicast traffic originating outside the Tenant Domain is transmitted with the label corresponding to the SBD, as specified in the ingress EVPN PE's SBD-IMET route.

3.2.5.2. Using Wildcard S-PMSI A-D Routes to Advertise Inclusive Tunnels Specific to IP Multicast

The procedures of this section apply when (and only when) it is desired to transmit IP multicast traffic on an inclusive tunnel but not on the same tunnel used to transmit BUM traffic.

However, these procedures do NOT apply when the tunnel type is IR or BIER, EXCEPT in the case where it is necessary to interwork between non-OISM PEs and OISM PEs, as specified in [Section 5](#).

Each EVPN PE attached to the given Tenant Domain **MUST** originate an SBD-SPMSI A-D route. The NLRI of that route **MUST** contain (C-*,C-*) (see [RFC6625]). Additional rules for constructing that route are given in [Section 3.2.1](#).

In addition, an EVPN PE **MUST** originate an S-PMSI A-D route containing (C-*,C-*) in its NLRI for each of the other BDs, in the given Tenant Domain, to which it is attached. All such routes **MUST** carry the SBD-RT. This ensures that those routes are imported by all EVPN PEs attached to the Tenant Domain.

A PE receiving these routes follows the procedures of [Section 2.2](#) to determine which BD the route is for.

If the MPLS Label field of the PTA contains zero, the specified tunnel is used only to carry frames of a single source BD.

If the MPLS Label field of the PTA does not contain zero, it **MUST** specify an upstream-assigned MPLS label that maps uniquely (in the context of the originating EVPN PE) to the source BD. The tunnel may be used to carry frames of multiple source BDs, and the apparent source BD for a particular packet is inferred from the label carried by the packet.

The EVPN PE advertising these S-PMSI A-D routes is specifying the default tunnel that it will use (as ingress PE) for transmitting IP multicast packets. The upstream-assigned label allows an egress PE to determine the apparent source BD of a given packet.

3.2.6. Selective Tunnels

An ingress EVPN PE for a given multicast flow or set of flows can always assign the flow to a particular P2MP tunnel by originating an S-PMSI A-D route whose NLRI identifies the flow or set of flows. The NLRI of the route could be (C-*,C-G) or (C-S,C-G). The S-PMSI A-D route **MUST** carry the SBD-RT so that it is imported by all EVPN PEs attached to the Tenant Domain.

An S-PMSI A-D route is for a particular source BD. It **MUST** carry the RT associated with that BD, and it **MUST** have the Tag ID for that BD in its NLRI.

When an EVPN PE imports an S-PMSI A-D route, it applies the rules of [Section 2.2](#) to associate the route with a particular BD.

Each such route **MUST** contain a PTA, as specified in [Section 3.2.5.2](#).

An egress EVPN PE interested in the specified flow or flows **MUST** join the specified tunnel. Procedures for joining the specified tunnel are specific to the tunnel type. (Note that if the tunnel type is RSVP-TE P2MP LSP, the Leaf Information Required (LIR) flag of the PTA **SHOULD NOT** be set. An ingress OISM PE knows which OISM EVPN PEs are interested in any given flow and hence can add them to the RSVP-TE P2MP tunnel that carries such flows.)

If the PTA does not specify a non-zero MPLS label, the apparent source BD of any packets that arrive on that tunnel is considered to be the BD associated with the route that carries the PTA. If the PTA does specify a non-zero MPLS label, the apparent source BD of any packets that arrive on that tunnel carrying the specified label is considered to be the BD associated with the route that carries the PTA.

It should be noted that, when either IR or BIER is used, there is no need for an ingress PE to use S-PMSI A-D routes to assign specific flows to selective tunnels. The procedures of [Section 3.3](#), along with the procedures of [Sections 3.2.2](#), [3.2.3](#), and [3.2.4](#), provide the functionality of selective tunnels without the need to use S-PMSI A-D routes.

3.3. Advertising SMET Routes

[\[RFC9251\]](#) allows an egress EVPN PE to express its interest in a particular multicast flow or set of flows by originating a SMET route. The NLRI of the SMET route identifies the flow or set of flows as (C-*,C-*), (C-*,C-G), or (C-S,C-G).

Each SMET route belongs to a particular BD. The Tag ID for the BD appears in the NLRI of the route, and the route carries the RT associated with that BD. From this <RT, tag> pair, other EVPN PEs can identify the BD to which a received SMET route belongs. (Remember though that the route may be carrying multiple RTs.)

There are three cases to consider:

Case 1: It is known that no BD of a Tenant Domain contains a multicast router.

In this case, an egress PE advertises its interest in a flow or set of flows by originating a SMET route that belongs to the SBD. We refer to this as an SBD-SMET route. The SBD-SMET route carries the SBD-RT and has the Tag ID for the SBD in its NLRI. SMET routes for the individual BDs are not needed, because there is no need for a PE that receives a SMET route to send a corresponding IGMP/MLD Join message on any of its ACs.

Case 2: It is known that more than one BD of a Tenant Domain may contain a multicast router.

This is much like Case 1. An egress PE advertises its interest in a flow or set of flows by originating an SBD-SMET route. The SBD-SMET route carries the SBD-RT and has the Tag ID for the SBD in its NLRI.

In this case, it is important to be sure that SMET routes for the individual BDs are not originated. For example, suppose that PE1 had local receivers for a given flow on both BD1 and BD2 and that it originated SMET routes for both those BDs. Then, PEs receiving those SMET routes might send IGMP/MLD Joins on both those BDs. This could cause externally sourced multicast traffic to enter the Tenant Domain at both BDs, which could result in duplication of data.

Note that if it is possible that more than one BD contains a tenant multicast router, then in order to receive multicast data originating from outside EVPN, the PEs **MUST** follow the procedures of [Section 6](#).

Case 3: It is known that only a single BD of a Tenant Domain contains a multicast router.

Suppose that an egress PE is attached to a BD on which there might be a tenant multicast router. (The tenant router is not necessarily on a segment that is attached to that PE.) And suppose that the PE has one or more ACs attached to that BD, which are interested in a given multicast flow. In this case, in addition to the SMET route for the SBD, the egress PE **MAY** originate a SMET route for that BD. This will enable the ingress PE(s) to send IGMP/MLD messages on ACs for the BD, as specified in [\[RFC9251\]](#). As long as that is the only BD on which there is a tenant multicast router, there is no possibility of duplication of data.

This document does not specify procedures for dynamically determining which of the three cases applies to a given deployment; the PEs of a given Tenant Domain **MUST** be provisioned to know which case applies.

As detailed in [\[RFC9251\]](#), a SMET route carries flags indicating whether IGMP (v1, v2, or v3) or MLD (v1 or v2) messages should be triggered on the ACs of the BD to which the SMET route belongs. For IGMP v3 and MLD v2, the Include/Exclude (IE) flag also indicates whether the source information in the SMET route is of an Include Group type or Exclude Group type. If an SBD PE needs to generate IGMP/MLD reports (as it is the case in [Section 6.2](#)) or the route is for an (S, G) state, the value of the flags **MUST** be set according to the rules in [\[RFC9251\]](#). Otherwise, the flags **SHOULD** be set to 0.

Note that a PE only needs to originate the set of SBD-SMET routes that are needed in order to receive multicast traffic that the PE is interested in. Suppose PE1 has ACs attached to BD1 that are interested in (C-*,C-G) traffic and ACs attached to BD2 that are interested in (C-S,C-G) traffic. A single SBD-SMET route specifying (C-*,C-G) will attract all the necessary flows.

As another example, suppose the ACs attached to BD1 are interested in (C-*,C-G) but not in (C-S,C-G), while the ACs attached to BD2 are interested in (C-S,C-G). A single SBD-SMET route specifying (C-*,C-G) will pull in all the necessary flows.

In other words, to determine the set of SBD-SMET routes that have to be sent for a given C-G, the PE has to merge the IGMP/MLD state for all the BDs (of the given Tenant Domain) to which it is attached.

Per [\[RFC9251\]](#), importing a SMET route for a particular BD will cause the IGMP/MLD state to be instantiated for the IRB interface to that BD. This also applies when the BD is the SBD.

However, traffic that originates in one of the actual BDs of a particular Tenant Domain **MUST NOT** be sent down the IRB interface that connects the L3 routing instance of that Tenant Domain to the SBD. That would cause duplicate delivery of traffic, since such traffic will have already been distributed throughout the Tenant Domain. Therefore, when setting up the IGMP/MLD state based on SBD-SMET routes, care must be taken to ensure that the IRB interface to the SBD is not added to the Outgoing Interface (OIF) list if the traffic originates within the Tenant Domain.

There are some multicast scenarios that make use of anycast sources. For example, two different sources may share the same anycast IP address, say S1, and each may transmit an (S1,G) multicast flow. In such a scenario, the two (S1,G) flows are typically identical. Ordinary PIM procedures will cause only one of the flows to be delivered to each receiver that has expressed interest in either (*,G) or (S1,G). However, the OISM procedures described in this document will result in both of the (S1,G) flows being distributed in the Tenant Domain, and duplicate delivery will result. Therefore, if there are receivers for (*,G) in a given Tenant Domain, there **MUST NOT** be anycast sources for G within that Tenant Domain. (This restriction could be lifted by defining additional procedures; however, that is outside the scope of this document.)

4. Constructing Multicast Forwarding State

4.1. Layer 2 Multicast State

An EVPN PE maintains Layer 2 multicast state for each BD to which it is attached. Note that this is used for forwarding IP multicast frames based on the inner IP header. The state is learned through IGMP/MLD snooping [RFC4541] and procedures in this document.

Let PE1 be an EVPN PE and BD1 be a BD to which it is attached. At PE1, BD1's Layer 2 multicast state for a given (C-S,C-G) or (C-*,C-G) governs the disposition of an IP multicast packet that is received by BD1's Layer 2 multicast function on an EVPN PE.

An IP multicast (S,G) packet is considered to have been received by BD1's Layer 2 multicast function in PE1 in the following cases:

- The packet is the payload of an Ethernet frame received by PE1 from an AC that attaches to BD1.
- The packet is the payload of an Ethernet frame whose apparent source BD is BD1, which is received by the PE1 over a tunnel from another EVPN PE.
- The packet is received from BD1's IRB interface (i.e., has been transmitted by PE1's L3 routing instance down BD1's IRB interface).

According to the procedures of this document, all transmissions of IP multicast packets from one EVPN PE to another are done at Layer 2. That is, the packets are transmitted as Ethernet frames, according to the Layer 2 multicast state.

Each Layer 2 multicast state (S,G) or (*,G) contains a set of outgoing interfaces (an OIF list). The disposition of an (S,G) multicast frame received by BD1's Layer 2 multicast function is determined as follows:

- The OIF list is taken from BD1's Layer 2 (S,G) state, or if there is no such (S,G) state, then it is taken from BD1's (*,G) state. (If neither state exists, the OIF list is considered to be null.)
- The rules of [Section 4.1.2](#) are applied to the OIF list. This will generally result in the frame being transmitted to some, but not all, elements of the OIF list.

Note that there is no Reverse Path Forwarding (RPF) check at Layer 2.

4.1.1. Constructing the OIF List

In this document, we have extended the procedures of [RFC9251] so that IMET and SMET routes for a particular BD are distributed not just to PEs that attach to that BD but to PEs that attach to any BD in the Tenant Domain. In this way, each PE attached to a given Tenant Domain learns, from another PE attached to the same Tenant Domain, the set of flows that are of interest to each of those other PEs. (If some PE attached to the Tenant Domain does not support [RFC9251], it will be assumed to be interested in all flows. Whether or not a particular remote PE supports [RFC9251] is determined by the presence of an Extended Community in its IMET route; this is specified in [RFC9251].) If a set of remote PEs are interested in a particular flow, the tunnels used to reach those PEs are added to the OIF list of the multicast states corresponding to that flow.

An EVPN PE may run IGMP/MLD snooping procedures [RFC4541] on each of its ACs in order to determine the set of flows of interest to each AC. (An AC is said to be interested in a given flow if it connects to a segment that has tenant systems interested in that flow.) If IGMP/MLD procedures are not being run on a given AC, that AC is considered to be interested in all flows. For each BD, the set of ACs interested in a given flow is determined, and the ACs of that set are added to the OIF list of that BD's multicast state for that flow.

The OIF list for each multicast state must also contain the IRB interface for the BD to which the state belongs.

Implementors should note that the OIF list of a multicast state will change from time to time as ACs and/or remote PEs either become interested in or lose interest in particular multicast flows.

4.1.2. Data Plane: Applying the OIF List to an (S,G) Frame

When an (S,G) multicast frame is received by the Layer 2 multicast function of a given EVPN PE, say PE1, its disposition depends upon (a) the way it was received, (b) the OIF list of the corresponding multicast state (see Section 4.1.1), (c) the eligibility of an AC to receive a given frame (see Section 4.1.2.1), and (d) its apparent source BD (see Section 3.2 for information about determining the apparent source BD of a frame received over a tunnel from another PE).

4.1.2.1. Eligibility of an AC to Receive a Frame

A given (S,G) multicast frame is eligible to be transmitted by a given PE, say PE1, on a given AC, say AC1, only if one of the following conditions holds:

1. Ethernet Segment Identifier (ESI) labels are being used, PE1 is the DF for the segment to which AC1 is connected, and the frame did not originate from that same segment (as determined by the ESI label).
2. The ingress PE for the frame is a remote PE, say PE2, local bias is being used, and PE2 is not connected to the same segment as AC1.

4.1.2.2. Applying the OIF List

Assume a given (S,G) multicast frame has been received by a given PE, say PE1. PE1 determines the apparent source BD of the frame, finds the Layer 2 (S,G) state for that BD (or the (*,G) state if there is no (S,G) state), and uses the OIF list from that state. (Note that if PE1 is not attached to the actual source BD, the apparent source BD will be the SBD.)

If PE1 has determined the frame's apparent source BD to be BD1 (which may or may not be the SBD), then the following cases should be considered:

1. The frame was received by PE1 from a local AC, say AC1, that attaches to BD1.
 - a. The frame **MUST** be sent on all local ACs of BD1 that appear in the OIF list, except for AC1 itself.
 - b. The frame **MUST** also be delivered to any other EVPN PEs that have interest in it. This is achieved as follows:
 - i. If (a) AR is being used, (b) PE1 is an AR-LEAF, and (c) the OIF list is non-null, PE1 **MUST** send the frame to the AR-REPLICATOR.
 - ii. Otherwise, the frame **MUST** be sent on all tunnels in the OIF list.
 - c. The frame **MUST** be sent to the local L3 routing instance by being sent up the IRB interface of BD1. It **MUST NOT** be sent up any other IRB interfaces.
2. The frame was received by PE1 over a tunnel from another PE. (See [Section 3.2](#) for the rules to determine the apparent source BD of a packet received from another PE. Note that if PE1 is not attached to the source BD, it will regard the SBD as the apparent source BD.)
 - a. The frame **MUST** be sent on all local ACs in the OIF list that connect to BD1 and that are eligible (per [Section 4.1.2.1](#)) to receive the frame.
 - b. The frame **MUST** be sent up the IRB interface of the apparent source BD. (Note that this may be the SBD.) The frame **MUST NOT** be sent up any other IRB interfaces.
 - c. If PE1 is not an AR-REPLICATOR, it **MUST NOT** send the frame to any other EVPN PEs. However, if PE1 is an AR-REPLICATOR, it **MUST** send the frame to all tunnels in the OIF list, except for the tunnel over which the frame was received.
3. The frame was received by PE1 from the BD1 IRB interface (i.e., the frame has been transmitted by PE1's L3 routing instance down the BD1 IRB interface), and BD1 is NOT the SBD.
 - a. The frame **MUST** be sent on all local ACs in the OIF list that are eligible, as per [Section 4.1.2.1](#), to receive the frame.
 - b. The frame **MUST NOT** be sent to any other EVPN PEs.
 - c. The frame **MUST NOT** be sent up any IRB interfaces.
4. The frame was received from the SBD IRB interface (i.e., has been transmitted by PE1's L3 routing instance down the SBD IRB interface).
 - a. The frame **MUST** be sent on all tunnels in the OIF list. This causes the frame to be delivered to any other EVPN PEs that have interest in it.

- b. The frame **MUST NOT** be sent on any local ACs.
- c. The frame **MUST NOT** be sent up any IRB interfaces.

4.2. Layer 3 Forwarding State

If an EVPN PE is performing IGMP/MLD procedures on the ACs of a given BD, it processes those messages at Layer 2 to help form the Layer 2 multicast state. It also sends those messages up that BD's IRB interface to the L3 routing instance of a particular Tenant Domain. This causes the (C-S,C-G) or (C-*,C-G) L3 state to be created/updated.

A Layer 3 multicast state has both an Input Interface (IIF) and an OIF list.

For a (C-S,C-G) state, if the source BD is present on the PE, the IIF is set to the IRB interface that attaches to that BD. Otherwise, the IIF is set to the SBD IRB interface.

For (C-*,C-G) states, traffic can arrive from any BD, so the IIF needs to be set to a wildcard value meaning "any IRB interface".

The OIF list of these states includes one or more of the IRB interfaces of the Tenant Domain. In general, maintenance of the OIF list does not require any EVPN-specific procedures. However, there is one EVPN-specific rule:

If the IIF is one of the IRB interfaces (or the wildcard meaning "any IRB interface"), then the SBD IRB interface **MUST NOT** be added to the OIF list. Traffic originating from within a particular EVPN Tenant Domain must not be sent down the SBD IRB interface, as such traffic has already been distributed to all EVPN PEs attached to that Tenant Domain.

Please also see [Section 6.1.1](#), which states a modification of this rule for the case where OISM is interworking with external Layer 3 multicast routing.

5. Interworking with Non-OISM EVPN PEs

It is possible that a given Tenant Domain will be attached to both OISM PEs and non-OISM PEs. Inter-subnet IP multicast should be possible and fully functional even if not all PEs attaching to a Tenant Domain can be upgraded to support OISM functionality.

Note that the non-OISM PEs are not required to have IRB support or support for [\[RFC9251\]](#). However, it is advantageous for the non-OISM PEs to support [\[RFC9251\]](#).

In this section, we will use the following terminology:

PE-S: The ingress PE for an (S,G) flow.

PE-R: An egress PE for an (S,G) flow.

BD-S: The source BD for an (S,G) flow. PE-S must have one or more ACs attached to BD-S, at least one of which attaches to host S.

BD-R: A BD that contains a host interested in the flow. The host is attached to PE-R via an AC that belongs to BD-R.

To allow OISM PEs to interwork with non-OISM PEs, a given Tenant Domain needs to contain one or more IP Multicast Gateways (IPMGs). An IPMG is an OISM PE with special responsibilities regarding the interworking between OISM and non-OISM PEs.

If a PE is functioning as an IPMG, it **MUST** signal this fact by setting the IPMG flag in the Multicast Flags EC that it attaches to its IMET routes. An IPMG **SHOULD** attach this EC, with the IPMG flag set, to all IMET routes it originates. Furthermore, if PE1 imports any IMET route from PE2 that has the EC present with the IPMG flag set, then the PE1 will assume that PE2 is an IPMG.

An IPMG Designated Forwarder (IPMG-DF) selection procedure is used to ensure that there is exactly one active IPMG-DF for any given BD at any given time. Details of the IPMG-DF selection procedure are in [Section 5.1](#). The IPMG-DF for a given BD, say BD-S, has special functions to perform when it receives (S,G) frames on that BD:

- If the frames are from a non-OISM PE-S:
 - The IPMG-DF forwards them to OISM PEs that do not attach to BD-S but have interest in (S,G).

Note that OISM PEs that do attach to BD-S will have received the frames on the BUM tunnel from the non-OISM PE-S.
 - The IPMG-DF forwards them to non-OISM PEs that have interest in (S,G) on ACs that do not belong to BD-S.

Note that if a non-OISM PE has multiple BDs (other than BD-S) with interest in (S,G), it will receive one copy of the frame for each such BD. This is necessary because the non-OISM PEs cannot move IP multicast traffic from one BD to another.
- If the frames are from an OISM PE, the IPMG-DF forwards them to non-OISM PEs that have interest in (S,G) on ACs that do not belong to BD-S.

If a non-OISM PE has interest in (S,G) on an AC belonging to BD-S, it will have received a copy of the (S,G) frame, encapsulated for BD-S, from the OISM PE-S (see [Section 3.2.2](#)). If the non-OISM PE has interest in (S,G) on one or more ACs belonging to BD-R1,...,BD-Rk where the BD-Ri are distinct from BD-S, the IPMG-DF needs to send it a copy of the frame for each BD-Ri.

If an IPMG receives a frame on a BD for which it is not the IPMG-DF, it just follows normal OISM procedures.

This section specifies several sets of procedures:

- the procedures that the IPMG-DF for a given BD needs to follow when receiving, on that BD, an IP multicast frame from a non-OISM PE;
- the procedures that the IPMG-DF for a given BD needs to follow when receiving, on that BD, an IP multicast frame from an OISM PE; and

- the procedures that an OISM PE needs to follow when receiving, on a given BD, an IP multicast frame from a non-OISM PE, when the OISM PE is not the IPMG-DF for that BD.

To enable OISM/non-OISM interworking in a given Tenant Domain, the Tenant Domain **MUST** have some EVPN PEs that can function as IPMGs. An IPMG must be configured with the SBD. It must also be configured with every BD of the Tenant Domain that exists on any of the non-OISM PEs of that domain. (Operationally, it may be simpler to configure the IPMG with all the BDs of the Tenant Domain.)

Of course, a non-OISM PE only needs to be configured with BDs for which it has ACs. An OISM PE that is not an IPMG only needs to be configured with the SBD and with the BDs for which it has ACs.

An IPMG **MUST** originate a wildcard SMET route (with (C-*,C-*) in the NLRI) for each BD in the Tenant Domain. This will cause it to receive all the IP multicast traffic that is sourced in the Tenant Domain. Note that non-OISM nodes that do not support [RFC9251] will send all the multicast traffic from a given BD to all PEs attached to that BD, even if those PEs do not originate a SMET route.

The interworking procedures vary somewhat depending upon whether packets are transmitted from PE to PE via IR or via P2MP tunnels. In this section, we do not consider the use of BIER due to the low likelihood of there being a non-OISM PE that supports BIER.

5.1. IPMG Designated Forwarder

Every PE that is eligible for selection as an IPMG-DF for a particular BD originates both an IMET route for that BD and an SBD-IMET route. As stated in [Section 5](#), these SBD-IMET routes carry a Multicast Flags EC with the IPMG flag set.

These SBD-IMET routes **SHOULD** also carry a DF Election EC. The DF Election EC and its use is specified in [RFC8584]. When the route is originated, the AC-DF bit in the DF Election EC **SHOULD NOT** be set. This bit is not used when selecting an IPMG-DF, i.e., it **MUST** be ignored by the receiver of an SBD-IMET route.

In the context of a given Tenant Domain, to select the IPMG-DF for a particular BD, say BD1, the IPMGs of the Tenant Domain perform the following procedures:

- From the set of received SBD-IMET routes for the given Tenant Domain, determine the candidate set of PEs that support IPMG functionality for that domain.
- From that candidate set, eliminate any PEs from which an IMET route for BD1 has not been received.
- Select a DF election algorithm as specified in [RFC8584]. Some of the possible algorithms can be found, e.g., in [RFC8584], [RFC7432], and [EVPN-DF].
- Apply the DF election algorithm (see [RFC8584]) to the candidate set of PEs. The winner becomes the IPMG-DF for BD1.

Note that even if a given PE supports MEG (Section 6.1.2) and/or PEG (Section 6.1.4) functionality, as well as IPMG functionality, its SBD-IMET routes carry only one DF Election EC.

5.2. Ingress Replication

The procedures of this section are used when IR is used to transmit packets from one PE to another.

When a non-OISM PE-S transmits a multicast frame from BD-S to another PE, say PE-R, PE-S will use the encapsulation specified in the BD-S IMET route that was originated by PE-R. This encapsulation will include the label that appears in the MPLS Label field of the PTA of the IMET route. If the tunnel type is VXLAN, the label is actually a Virtual Network Identifier (VNI); for other tunnel types, the label is an MPLS label. In either case, the frames are transmitted with a label that was assigned to a particular BD by the PE-R to which the frame is being transmitted.

To support OISM/non-OISM interworking, an OISM PE-R **MUST** originate, for each of its BDs, both an IMET route and an (C-*,C-*) S-PMSI A-D route. Note that even when IR is being used, interworking between OISM and non-OISM PEs requires the OISM PEs to follow the rules of Section 3.2.5.2, as modified below.

Non-OISM PEs will not understand S-PMSI A-D routes. So when a non-OISM PE-S transmits an IP multicast frame with a particular source BD to an IPMG, it encapsulates the frame using the label specified in that IPMG's BD-S IMET route. (This is just the procedure of [RFC7432].)

The (C-*,C-*) S-PMSI A-D route originated by a given OISM PE will have a PTA that specifies IR.

- If MPLS tunneling is being used, the MPLS Label field **SHOULD** contain a non-zero value, and the LIR flag **SHOULD** be zero. (The case where the MPLS Label field is zero or the LIR flag is set is outside the scope of this document.)
- If the tunnel encapsulation is VXLAN, the MPLS Label field **MUST** contain a non-zero value, and the LIR flag **MUST** be zero.

When an OISM PE-S transmits an IP multicast frame to an IPMG, it will use the label specified in that IPMG's (C-*,C-*) S-PMSI A-D route.

When a PE originates both an IMET route and a (C-*,C-*) S-PMSI A-D route, the values of the MPLS Label field in the respective PTAs must be distinct. Further, each **MUST** map uniquely (in the context of the originating PE) to the route's BD.

As a result, an IPMG receiving an MPLS-encapsulated IP multicast frame can always tell by the label whether the frame's ingress PE is an OISM PE or a non-OISM PE. When an IPMG receives a VXLAN-encapsulated IP multicast frame, it may need to determine the identity of the ingress PE from the outer IP encapsulation; it can then determine whether the ingress PE is an OISM PE or a non-OISM PE by looking at the IMET route from that PE.

Suppose an IPMG receives an IP multicast frame from another EVPN PE in the Tenant Domain and the IPMG is not the IPMG-DF for the frame's source BD. Then, the IPMG performs only the ordinary OISM functions; it does not perform the IPMG-specific functions for that frame. In the

remainder of this section, when we discuss the procedures applied by an IPMG when it receives an IP multicast frame, we are presuming that the source BD of the frame is a BD for which the IPMG is the IPMG-DF.

We have two basic cases to consider: (1) a frame's ingress PE is a non-OISM node and (2) a frame's ingress PE is an OISM node.

5.2.1. Ingress PE is Non-OISM

In this case, a non-OISM PE, say PE-S, has received an (S,G) multicast frame over an AC that is attached to a particular BD, say BD-S. By virtue of normal EVPN procedures, PE-S has sent a copy of the frame to every PE-R (both OISM and non-OISM) in the Tenant Domain that is attached to BD-S. If the non-OISM node supports [\[RFC9251\]](#), only PEs that have expressed interest in (S,G) receive the frame. The IPMG will have expressed interest via a (C-*,C-*) SMET route and thus receives the frame.

Any OISM PE (including an IPMG) receiving the frame will apply normal OISM procedures. As a result, it will deliver the frame to any of its local ACs (in BD-S or in any other BD) that have interest in (S,G).

An OISM PE that is also the IPMG-DF for a particular BD, say BD-S, has additional procedures that it applies to frames received on BD-S from non-OISM PEs:

1. When the IPMG-DF for BD-S receives an (S,G) frame from a non-OISM node, it **MUST** forward a copy of the frame to every OISM PE that is NOT attached to BD-S but has interest in (S,G). The copy sent to a given OISM PE-R must carry the label that PE-R has assigned to the SBD in an S-PMSI A-D route. The IPMG **MUST NOT** do any IP processing of the frame's IP payload. TTL decrement and other IP processing will be done by PE-R, per the normal OISM procedures. There is no need for the IPMG to include an ESI label in the frame's tunnel encapsulation, because it is already known that the frame's source BD has no presence on PE-R. There is also no need for the IPMG to modify the frame's MAC SA.
2. In addition, when the IPMG-DF for BD-S receives an (S,G) frame from a non-OISM node, it may need to forward copies of the frame to other non-OISM nodes. Before it does so, it **MUST** decapsulate the (S,G) packet and do the IP processing (e.g., TTL decrement). Suppose PE-R is a non-OISM node that has an AC to BD-R, where BD-R is not the same as BD-S, and that AC has interest in (S,G). The IPMG must then encapsulate the (S,G) packet (after the IP processing has been done) in an Ethernet header. The MAC SA field will have the MAC address of the IPMG's IRB interface for BD-R. The IPMG then sends the frame to PE-R. The tunnel encapsulation will carry the label that PE-R advertised in its IMET route for BD-R. There is no need to include an ESI label, as the source and destination BDs are known to be different.

Note that if a non-OISM PE-R has several BDs (other than BD-S) with local ACs that have interest in (S,G), the IPMG will send it one copy for each such BD. This is necessary because the non-OISM PE cannot move packets from one BD to another.

There may be deployment scenarios in which every OISM PE is configured with every BD that is present on any non-OISM PE. In such scenarios, the procedures of item 1 above will not actually result in the transmission of any packets. Hence, if it is known a priori that this deployment scenario exists for a given Tenant Domain, the procedures of item 1 above can be disabled.

5.2.2. Ingress PE is OISM

In this case, an OISM PE, say PE-S, has received an (S,G) multicast frame over an AC that attaches to a particular BD, say BD-S.

By virtue of receiving all the IMET routes for BD-S, PE-S will know all the PEs attached to BD-S. By virtue of normal OISM procedures:

- PE-S will send a copy of the frame to every OISM PE-R (including the IPMG) in the Tenant Domain that is attached to BD-S and has interest in (S,G). The copy sent to a given PE-R carries the label that the PE-R has assigned to BD-S in its (C-*,C-*) S-PMSI A-D route.
- PE-S will also transmit a copy of the (S,G) frame to every OISM PE-R that has interest in (S,G) but is not attached to BD-S. The copy will contain the label that the PE-R has assigned to the SBD. (As specified in [Section 5.2.1](#), an IPMG is assumed to have indicated interest in all multicast flows.)
- PE-S will also transmit a copy of the (S,G) frame to every non-OISM PE-R that is attached to BD-S. It does this using the label advertised by that PE-R in its IMET route for BD-S.

The PE-Rs follow their normal procedures. An OISM PE that receives the (S,G) frame on BD-S applies the OISM procedures to deliver the frame to its local ACs as necessary. A non-OISM PE that receives the (S,G) frame on BD-S delivers the frame only to its local BD-S ACs as necessary.

Suppose that a non-OISM PE-R has interest in (S,G) on a BD that is different than BD-S, say BD-R. If the non-OISM PE-R is attached to BD-S, the OISM PE-S will send it the original (S,G) multicast frame, but the non-OISM PE-R will not be able to send the frame to ACs that are not in BD-S. If PE-R is not even attached to BD-S, the OISM PE-S will not send it a copy of the frame at all, because PE-R is not attached to the SBD. In these cases, the IPMG needs to relay the (S,G) multicast traffic from OISM PE-S to non-OISM PE-R.

When the IPMG-DF for BD-S receives an (S,G) frame from an OISM PE-S, it has to forward it to every non-OISM PE-R that has interest in (S,G) on a BD-R that is different than BD-S. The IPMG **MUST** decapsulate the IP multicast packet, do the IP processing, re-encapsulate it for BD-R (changing the MAC SA to the IPMG's own MAC address for BD-R), and send a copy of the frame to PE-R. Note that a given non-OISM PE-R will receive multiple copies of the frame if it has multiple BDs on which there is interest in the frame.

5.3. P2MP Tunnels

When IR is used to distribute the multicast traffic among the EVPN PEs, the procedures described in [Section 5.2](#) ensure that there will be no duplicate delivery of multicast traffic. That is, no egress PE will ever send a frame twice on any given AC. If P2MP tunnels are being used to distribute the multicast traffic, it is necessary to have additional procedures to prevent duplicate delivery.

At the present time, it is not clear that there will be a use case in which OISM nodes need to interwork with non-OISM nodes that use P2MP tunnels. If it is determined that there is such a use case, procedures for P2MP may be specified in a separate document.

6. Traffic to/from Outside the EVPN Tenant Domain

In this section, we discuss scenarios where a multicast source outside a given EVPN Tenant Domain sends traffic to receivers inside the domain (as well as, possibly, to receivers outside the domain). This requires the OISM procedures to interwork with various Layer 3 multicast routing procedures.

In this section, we assume that the Tenant Domain is not being used as an intermediate transit network for multicast traffic; that is, we do not consider the case where the Tenant Domain contains multicast routers that will receive traffic from sources outside the domain and forward the traffic to receivers outside the domain. The transit scenario is considered in [Section 7](#).

We can divide the non-transit scenarios into two classes:

1. One or more of the EVPN PE routers provide the functionality needed to interwork with Layer 3 multicast routing procedures.
2. A single BD in the Tenant Domain contains external multicast routers (tenant multicast routers), and those tenant multicast routers are used to interwork, on behalf of the entire Tenant Domain, with Layer 3 multicast routing procedures.

6.1. Layer 3 Interworking via EVPN OISM PEs

6.1.1. General Principles

Sometimes it is necessary to interwork an EVPN Tenant Domain with an external Layer 3 multicast domain (the external domain), e.g., a PIM or MVPN domain. This is needed to allow EVPN tenant systems to receive multicast traffic from sources (external sources) outside the EVPN Tenant Domain. It is also needed to allow receivers (external receivers) outside the EVPN Tenant Domain to receive traffic from sources inside the Tenant Domain.

In order to allow interworking between an EVPN Tenant Domain and an external domain, one or more OISM PEs must be L3 Gateways. An L3 Gateway participates both in the OISM procedures and in the L3 multicast routing procedures of the external domain, as shown in the following figure.

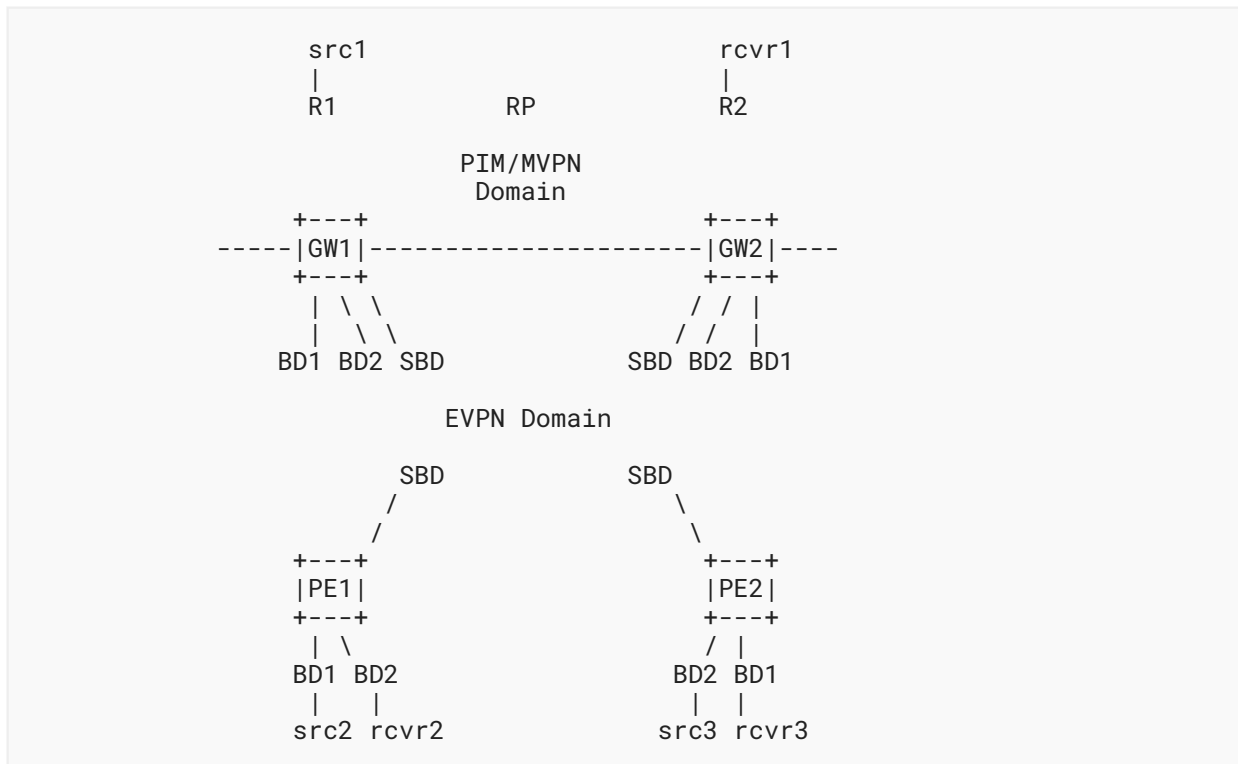

Figure 1: Interworking via OISM PEs

An L3 Gateway that has interest in receiving (S,G) traffic must be able to determine the best route to S. If an L3 Gateway has interest in (*,G), it must be able to determine the best route to G's RP. In these interworking scenarios, the L3 Gateway must be running a Layer 3 unicast routing protocol. Via this protocol, it imports unicast routes (either IP routes or VPN-IP routes) from routers other than EVPN PEs. And since there may be multicast sources inside the EVPN Tenant Domain, the EVPN PEs also need to export, either as IP routes or as VPN-IP routes (depending upon the external domain), unicast routes to those sources.

When selecting the best route to a multicast source or RP, an L3 Gateway might have a choice between an EVPN route and an IP/VPN-IP route. When such a choice exists, the L3 Gateway **SHOULD** always prefer the EVPN route. This will ensure that when traffic originates in the Tenant Domain and has a receiver in the Tenant Domain, the path to that receiver will remain within the EVPN Tenant Domain, even if the source is also reachable via a routed path. This also provides protection against sub-optimal routing that might occur if two EVPN PEs export IP/VPN-IP routes and each imports the other's IP/VPN-IP routes.

[Section 4.2](#) discusses the way Layer 3 multicast states are constructed by OISM PEs. These Layer 3 multicast states have IRB interfaces as their IIF and OIF list entries and are the basis for interworking OISM with other Layer 3 multicast procedures such as MVPN or PIM. From the perspective of the Layer 3 multicast procedures running in a given L3 Gateway, an EVPN Tenant Domain is a set of IRB interfaces.

When interworking an EVPN Tenant Domain with an external domain, the L3 Gateway's Layer 3 multicast states will not only have IRB interfaces as IIF and OIF list entries but also other interfaces that lead outside the Tenant Domain. For example, when interworking with MVPN, the multicast states may have MVPN tunnels as well as IRB interfaces as IIF or OIF list members. When interworking with PIM, the multicast states may have PIM-enabled non-IRB interfaces as IIF or OIF list members.

As long as a Tenant Domain is not being used as an intermediate transit network for IP multicast traffic, it is not necessary to enable PIM on its IRB interfaces.

In general, an L3 Gateway has the following responsibilities:

- It exports, to the external domain, unicast routes to those multicast sources in the EVPN Tenant Domain that are locally attached to the L3 Gateway.
- It imports, from the external domain, unicast routes to multicast sources that are in the external domain.
- It executes the procedures necessary to draw externally sourced multicast traffic that is of interest to locally attached receivers in the EVPN Tenant Domain. When such traffic is received, the traffic is sent down the IRB interfaces of the BDs on which the locally attached receivers reside.

One of the L3 Gateways in a given Tenant Domain becomes the DR for the SBD (see [Section 6.1.2.4](#)). This L3 Gateway has the following additional responsibilities:

- It exports, to the external domain, unicast routes to multicast sources in the EVPN Tenant Domain that are not locally attached to any L3 Gateway.
- It imports, from the external domain, unicast routes to multicast sources that are in the external domain.
- It executes the procedures necessary to draw externally sourced multicast traffic that is of interest to receivers in the EVPN Tenant Domain that are not locally attached to an L3 Gateway. When such traffic is received, the traffic is sent down the SBD IRB interface. OISM procedures already described in this document will then ensure that the IP multicast traffic gets distributed throughout the Tenant Domain to any EVPN PEs that have interest in it. Thus, to an OISM PE that is not an L3 Gateway, the externally sourced traffic will appear to have been sourced on the SBD.

In order for this to work, some special care is needed when an L3 Gateway creates or modifies a Layer 3 (*,G) multicast state. Suppose group G has both external sources (sources outside the EVPN Tenant Domain) and internal sources (sources inside the EVPN Tenant Domain). [Section 4.2](#) states that when there are internal sources, the SBD IRB interface must not be added to the OIF list of the (*,G) state. Traffic from internal sources will already have been delivered to all the EVPN PEs that have interest in it. However, if the OIF list of the (*,G) state does not contain its SBD IRB interface, then traffic from external sources will not get delivered to other EVPN PEs.

One way of handling this is the following. When an L3 Gateway receives (S,G) traffic from other than an IRB interface, and the traffic corresponds to a Layer 3 (*,G) state, the L3 Gateway can create (S,G) state. The IIF will be set to the external interface over which the traffic is expected.

The OIF list will contain the SBD IRB interface, as well as the IRB interfaces of any other BDs attached to the PEG DR that have locally attached receivers with interest in the (S,G) traffic. The (S,G) state will ensure that the external traffic is sent down the SBD IRB interface. The following text will assume this procedure; however, other implementation techniques may also be possible.

If a particular BD is attached to several L3 Gateways, one of the L3 Gateways becomes the DR for that BD (see [Section 6.1.2.4](#)). If the interworking scenario requires FHR functionality, it is generally the DR for a particular BD that is responsible for performing that functionality on behalf of the source hosts on that BD (e.g., if the interworking scenario requires that PIM Register messages be sent by an FHR, the DR for a given BD would send the PIM Register messages for sources on that BD). Although, note that the DR for the SBD does not perform FHR functionality on behalf of external sources.

An optional alternative is to have each L3 Gateway perform FHR functionality for locally attached sources. Then, the DR would only have to perform FHR functionality on behalf of sources that are locally attached to itself AND sources that are not attached to any L3 Gateway.

NB: If it is possible that more than one BD contains a tenant multicast router, then a PE receiving a SMET route for that BD **MUST NOT** reconstruct IGMP/MLD Join Reports from the SMET route and **MUST NOT** transmit any such IGMP/MLD Join Reports on its local ACs attaching to that BD. Otherwise, multicast traffic may be duplicated.

6.1.2. Interworking with MVPN

In this section, we specify the procedures necessary to allow EVPN PEs running OISM procedures to interwork with L3VPN PEs that run BGP-based MVPN [[RFC6514](#)] procedures. More specifically, the procedures herein allow a given EVPN Tenant Domain to become part of an L3VPN/MVPN and support multicast flows where either of the following occurs:

- The source of a given multicast flow is attached to an Ethernet segment whose BD is part of an EVPN Tenant Domain, and one or more receivers of the flow are attached to the network via L3VPN/MVPN. (Other receivers may be attached to the network via EVPN.)
- The source of a given multicast flow is attached to the network via L3VPN/MVPN, and one or more receivers of the flow are attached to an Ethernet segment that is part of an EVPN Tenant Domain. (Other receivers may be attached via L3VPN/MVPN.)

In this interworking model, existing L3VPN/MVPN PEs are unaware that certain sources or receivers are part of an EVPN Tenant Domain. The existing L3VPN/MVPN nodes run only their standard procedures and are entirely unaware of EVPN. Interworking is achieved by having some or all of the EVPN PEs function as L3 Gateways running L3VPN/MVPN procedures, as detailed in the following subsections.

In this section, we assume that there are no tenant multicast routers on any of the EVPN-attached Ethernet segments. (Of course, there may be multicast routers in the L3VPN.) Consideration of the case where there are tenant multicast routers is addressed in [Section 7](#).

To support MVPN/EVPN interworking, we introduce the notion of an MVPN/EVPN Gateway (MEG).

A MEG is an L3 Gateway (see [Section 6.1.1](#)); hence, it is both an OISM PE and an L3VPN/MVPN PE. For a given EVPN Tenant Domain, it will have an IP-VRF. If the Tenant Domain is part of an L3VPN/MVPN, the IP-VRF also serves as an L3VPN VRF [[RFC4364](#)]. The IRB interfaces of the IP-VRF are considered to be VRF interfaces of the L3VPN VRF. The L3VPN VRF may also have other local VRF interfaces that are not EVPN IRB interfaces.

The VRF on the MEG will import VPN-IP routes [[RFC4364](#)] from other L3VPN PE routers. It will also export VPN-IP routes to other L3VPN PE routers. In order to do so, it must be appropriately configured with the RTs used in the L3VPN to control the distribution of the VPN-IP routes. In general, these RTs will be different than the RTs used for controlling the distribution of EVPN routes, as there is no need to distribute EVPN routes to L3VPN-only PEs and no reason to distribute L3VPN/MVPN routes to EVPN-only PEs.

Note that the RDs in the imported VPN-IP routes will not necessarily conform to the EVPN rules (as specified in [[RFC7432](#)]) for creating RDs. Therefore, a MEG **MUST NOT** expect the RDs of the VPN-IP routes to be of any particular format other than what is required by the L3VPN/MVPN specifications.

The VPN-IP routes that a MEG exports to L3VPN are subnet routes and/or host routes for the multicast sources that are part of the EVPN Tenant Domain. The exact set of routes that need to be exported is discussed in [Section 6.1.2.2](#).

Each IMET route originated by a MEG **SHOULD** carry a Multicast Flags Extended Community with the MEG flag set, indicating that the originator of the IMET route is a MEG. However, PE1 will consider PE2 to be a MEG if PE1 imports at least one IMET route from PE2 that carries the Multicast Flags EC with the MEG flag set.

All the MEGs of a given Tenant Domain attach to the SBD of that domain, and one of them is selected to be the SBD's Designated Router (the MEG SBD-DR) for the domain. The selection procedure is discussed in [Section 6.1.2.4](#).

In this model of operation, MVPN procedures and EVPN procedures are largely independent. In particular, there is no assumption that MVPN and EVPN use the same kind of tunnels. Thus, no special procedures are needed to handle the common scenarios where, e.g., EVPN uses VXLAN tunnels but MVPN uses MPLS P2MP tunnels, or where EVPN uses IR but MVPN uses MPLS P2MP tunnels.

Similarly, no special procedures are needed to prevent duplicate data delivery on Ethernet segments that are multihomed.

The MEG does have some special procedures (described below) for interworking between EVPN and MVPN; these have to do with selection of the Upstream PE for a given multicast source, with the exporting of VPN-IP routes and with the generation of MVPN C-multicast routes triggered by the installation of SMET routes.

6.1.2.1. MVPN Sources with EVPN Receivers

6.1.2.1.1. Identifying MVPN Sources

Consider a multicast source S. It is possible that a MEG will import both an EVPN unicast route to S and a VPN-IP route (or an ordinary IP route), where the prefix length of each route is the same. In order to draw (S,G) multicast traffic for any group G, the MEG **SHOULD** use the EVPN route rather than the VPN-IP or IP route to determine the Upstream PE (see [Section 5](#) of [RFC6513]).

Doing so ensures that when an EVPN tenant system desires to receive a multicast flow from another EVPN tenant system, the traffic from the source to that receiver stays within the EVPN domain. This prevents problems that might arise if there is a unicast route via L3VPN to S but no multicast routers along the routed path. This also prevents problem that might arise as a result of the fact that the MEGs will import each others' VPN-IP routes.

In [Section 6.1.2.1.2](#), we describe the procedures to be used when the selected route to S is a VPN-IP route.

6.1.2.1.2. Joining a Flow from an MVPN Source

Consider a tenant system, say R, on a particular BD, say BD-R. Suppose R wants to receive (S,G) multicast traffic, where source S is not attached to any PE in the EVPN Tenant Domain but is attached to an MVPN PE.

- Suppose R is on a singly homed Ethernet segment of BD-R and that segment is attached to PE1, where PE1 is a MEG. PE1 learns via IGMP/MLD listening that R is interested in (S,G). PE1 determines from its VRF that there is no route to S within the Tenant Domain (i.e., no EVPN RT-2 route matching on S's IP address) but that there is a route to S via L3VPN (i.e., the VRF contains a subnet or host route to S that was received as a VPN-IP route). Thus, PE1 originates (if it hasn't already) an MVPN C-multicast Source Tree Join (S,G) route. The route is constructed according to normal MVPN procedures.

The Layer 2 multicast state is constructed as specified in [Section 4.1](#).

In the Layer 3 multicast state, the IIF is the appropriate MVPN tunnel, and the IRB interface to BD-R is added to the OIF list.

When PE1 receives (S,G) traffic from the appropriate MVPN tunnel, it performs IP processing of the traffic and then sends the traffic down its IRB interface to BD-R. Following normal OISM procedures, the (S,G) traffic will be encapsulated for Ethernet and sent on the AC to which R is attached.

- Suppose R is on a singly homed Ethernet segment of BD-R and that segment is attached to PE1, where PE1 is an OISM PE but is NOT a MEG. PE1 learns via IGMP/MLD listening that R is interested in (S,G). PE1 follows normal OISM procedures, originating an SBD-SMET route for (S,G); this route will be received by all the MEGs of the Tenant Domain, including the MEG SBD-DR. From PE1's IMET routes, the MEG SBD-DR can determine whether or not PE1 is itself a MEG. If PE1 is not a MEG, the MEG SBD-DR will originate (if it hasn't already) an MVPN C-multicast Source Tree Join (S,G) route. This will cause the MEG SBD-DR to receive (S,G) traffic on an MVPN tunnel.

The Layer 2 multicast state is constructed as specified in [Section 4.1](#).

In the Layer 3 multicast state, the IIF is the appropriate MVPN tunnel, and the IRB interface to the SBD is added to the OIF list.

When the MEG SBD-DR receives (S,G) traffic on an MVPN tunnel, it performs IP processing of the traffic and then sends the traffic down its IRB interface to the SBD. Following normal OISM procedures, the traffic will be encapsulated for Ethernet and delivered to all PEs in the Tenant Domain that have interest in (S,G), including PE1.

- If R is on a multihomed Ethernet segment of BD-R, one of the PEs attached to the segment will be its DF (following normal EVPN procedures), and the DF will know (via IGMP/MLD listening or the procedures of [\[RFC9251\]](#)) that a tenant system reachable via one of its local ACs to BD-R is interested in (S,G) traffic. The DF is responsible for originating an SBD-SMET route for (S,G), following normal OISM procedures. If the DF is a MEG, it **MUST** originate the corresponding MVPN C-multicast Source Tree Join (S,G) route; if the DF is not a MEG, the MEG SBD-DR SBD **MUST** originate the C-multicast route when it receives the SMET route.

Optionally, if the non-DF is a MEG, it **MAY** originate the corresponding MVPN C-multicast Source Tree Join (S,G) route. This will cause the traffic to flow to both the DF and the non-DF, but only the DF will forward the traffic out an AC. This allows for quicker recovery if the DF's local AC to R fails.

- If R is attached to a non-OISM PE, it will receive the traffic via an IPMG, as specified in [Section 5](#).

If an EVPN-attached receiver is interested in (*,G) traffic, and if it is possible for there to be sources of (*,G) traffic that are attached only to L3VPN nodes, the MEGs will have to know the group-to-RP mappings. That will enable them to originate MVPN C-multicast Shared Tree Join (*,G) routes and to send them toward the RP. (Since we are assuming in this section that there are no tenant multicast routers attached to the EVPN Tenant Domain, the RP must be attached via L3VPN. Alternatively, the MEG itself could be configured to function as an RP for group G.)

The Layer 2 multicast states are constructed as specified in [Section 4.1](#).

In the Layer 3 (*,G) multicast state, the IIF is the appropriate MVPN tunnel. A MEG will add its IRB interfaces to the (*,G) OIF list for any BDs containing locally attached receivers. If there are receivers attached to other EVPN PEs, then whenever (S,G) traffic from an external source matches a (*,G) state, the MEG will create (S,G) state, with the MVPN tunnel as the IIF, the OIF list copied from the (*,G) state, and the SBD IRB interface added to the OIF list. (Please see the discussion in [Section 6.1.1](#) regarding the inclusion of the SBD IRB interface in a (*,G) state; the SBD IRB interface is only used in the OIF list for traffic from external sources.)

Normal MVPN procedures will then result in the MEG getting the (*,G) traffic from all the multicast sources for G that are attached via L3VPN. This traffic arrives on MVPN tunnels. When the MEG removes the traffic from these tunnels, it does the IP processing. If there are any receivers on a given BD, say BD-R, that are attached via local EVPN ACs, the MEG sends the traffic down its BD-R IRB interface. If there are any other EVPN PEs that are interested in the (*,G) traffic, the MEG sends the traffic down the SBD IRB interface. Normal OISM procedures then distribute the traffic as needed to other EVPN PEs.

6.1.2.2. EVPN Sources with MVPN Receivers

6.1.2.2.1. General Procedures

Consider the case where an EVPN tenant system S is sending IP multicast traffic to group G and there is a receiver R for the (S,G) traffic that is attached to the L3VPN but not attached to the EVPN Tenant Domain. (In this document, we assume that the L3VPN-/MVPN-only nodes will not have any special procedures to deal with the case where a source is inside an EVPN domain.)

In this case, an L3VPN PE through which R can be reached has to send an MVPN C-multicast Join (S,G) route to one of the MEGs that is attached to the EVPN Tenant Domain. For this to happen, the L3VPN PE must have imported a VPN-IP route for S (either a host route or a subnet route) from a MEG.

If a MEG determines that there is multicast source transmitting on one of its ACs, the MEG **SHOULD** originate a VPN-IP host route for that source. This determination **SHOULD** be made by examining the IP multicast traffic that arrives on the ACs. (It **MAY** be made by provisioning.) A MEG **SHOULD NOT** export a VPN-IP host route for any IP address that is not known to be a multicast source (unless it has some other reason for exporting such a route). The VPN-IP host route for a given multicast source **MUST** be withdrawn if the source goes silent for a configurable period of time or if it can be determined that the source is no longer reachable via a local AC.

A MEG **SHOULD** also originate a VPN-IP subnet route for each of the BDs in the Tenant Domain.

VPN-IP routes exported by a MEG must carry any attributes or Extended Communities that are required by L3VPN and MVPN. In particular, a VPN-IP route exported by a MEG must carry a VRF Route Import Extended Community corresponding to the IP-VRF from which it is imported and a Source AS Extended Community.

As a result, if S is attached to a MEG, the L3VPN nodes will direct their MVPN C-multicast Join routes to that MEG. Normal MVPN procedures will cause the traffic to be delivered to the L3VPN nodes. The Layer 3 multicast state for (S,G) will have the MVPN tunnel on its OIF list. The IIF will be the IRB interface leading to the BD containing S.

If S is not attached to a MEG, the L3VPN nodes will direct their C-multicast Join routes to whichever MEG appears to be on the best route to S's subnet. Upon receiving the C-multicast Join, that MEG will originate an EVPN SMET route for (S,G). As a result, the MEG will receive the (S,G) traffic at Layer 2 via the OISM procedures. The (S,G) traffic will be sent up the appropriate IRB interface, and the Layer 3 MVPN procedures will ensure that the traffic is delivered to the L3VPN nodes that have requested it. The Layer 3 multicast state for (S,G) will have the MVPN tunnel in the OIF list, and the IIF will be one of the following:

- If S belongs to a BD that is attached to the MEG, the IIF will be the IRB interface to that BD.
- Otherwise, the IIF will be the SBD IRB interface.

Note that this works even if S is attached to a non-OISM PE, per the procedures of [Section 5](#).

6.1.2.2.2. Any-Source Multicast (ASM) Groups

Suppose the MEG SBD-DR learns that one of the PEs in its Tenant Domain is interested in (*,G) traffic, where G is an ASM group. If there are no tenant multicast routers, the MEG SBD-DR **SHOULD** perform the First Hop Router (FHR) functionality for group G on behalf of the Tenant Domain, as described in [RFC7761]. This means that the MEG SBD-DR must know the identity of the RP for each group, must send Register messages to the RP, etc.

If the MEG SBD-DR is to be the FHR for the Tenant Domain, it must see all the multicast traffic that is sourced from within the domain and destined to an ASM group address. The MEG can ensure this by originating an SBD-SMET route for (*,*).

(As a possible optimization, an SBD-SMET route for (*, any ASM group) may be defined in a separate document.)

In some deployment scenarios, it may be preferred that the MEG that receives the (S,G) traffic over an AC be the one providing the FHR functionality. This behavior is **OPTIONAL**. If this option is used, it **MUST** be ensured that the MEG DR does not provide the FHR functionality for (S,G) traffic that is attached to another MEG; FHR functionality for (S,G) traffic from a particular source S **MUST** be provided by only a single router.

Other deployment scenarios are also possible. For example, one might want to configure the MEGs themselves to be RPs. In this case, the RPs would have to exchange with each other information about which sources are active. The method exchanging such information is outside the scope of this document.

6.1.2.2.3. Source on Multihomed Segment

Suppose S is attached to a segment that is all-active multihomed to PE1 and PE2. If S is transmitting to two groups, say G1 and G2, it is possible that PE1 will receive the (S,G1) traffic from S, whereas PE2 will receive the (S,G2) traffic from S.

This creates an issue for MVPN/EVPN interworking, because there is no way to cause L3VPN/MVPN nodes to select PE1 as the ingress PE for (S,G1) traffic while selecting PE2 as the ingress PE for (S,G2) traffic.

However, the following procedure ensures that the IP multicast traffic will still flow, even if the L3VPN/MVPN nodes pick the wrong EVPN PE as the Upstream PE for, e.g., the (S,G1) traffic.

Suppose S is on an Ethernet segment, belonging to BD1, that is multihomed to both PE1 and PE2, where PE1 is a MEG. And suppose that IP multicast traffic from S to G travels over the AC that attaches the segment to PE2. If PE1 receives a C-multicast Source Tree Join (S,G) route, it **MUST** originate a SMET route for (S,G). Normal OISM procedures will then cause PE2 to send the (S,G) traffic to PE1 on an EVPN IP multicast tunnel. Normal OISM procedures will also cause PE1 to send the (S,G) traffic up its BD1 IRB interface. Normal MVPN procedures will then cause PE1 to forward the traffic on an MVPN tunnel. In this case, the routing is not optimal, but the traffic does flow correctly.

6.1.2.3. Obtaining Optimal Routing of Traffic between MVPN and EVPN

The routing of IP multicast traffic between MVPN nodes and EVPN nodes will be optimal as long as there is a MEG along the optimal route. There are various deployment strategies that can be used to obtain optimal routing between MVPN and EVPN.

In one such scenario, a Tenant Domain will have a small number of strategically placed MEGs. For example, a data center may have a small number of MEGs that connect it to a wide-area network. Then, the optimal route into or out of the data center would be through the MEGs.

In this scenario, the MEGs do not need to originate VPN-IP host routes for the multicast sources; they only need to originate VPN-IP subnet routes. The internal structure of the EVPN is completely hidden from the MVPN node. EVPN actions, such as MAC Mobility and Mass Withdrawal [RFC7432], have zero impact on the MVPN control plane.

While this deployment scenario provides the most optimal routing and has the least impact on the installed based of MVPN nodes, it does complicate network planning considerations.

Another way of providing routing that is close to optimal is to turn each EVPN PE into a MEG. Then, routing of MVPN-to-EVPN traffic is optimal. However, routing of EVPN-to-MVPN traffic is not guaranteed to be optimal when a source host is on a multihomed Ethernet segment (as discussed in Section 6.1.2.2.)

The obvious disadvantage of this method is that it requires every EVPN PE to be a MEG.

The procedures specified in this document allow an operator to add MEG functionality to any subset of its EVPN OISM PEs. This allows an operator to make whatever trade-offs deemed appropriate between optimal routing and MEG deployment.

6.1.2.4. Selecting the MEG SBD-DR

Every PE that is eligible for selection as the MEG SBD-DR originates an SBD-IMET route. As stated in Section 5, these SBD-IMET routes carry a Multicast Flags EC with the MEG flag set.

These SBD-IMET routes **SHOULD** also carry a DF Election EC. The DF Election EC and its use are specified in [RFC8584]. When the route is originated, the AC-DF bit in the DF Election EC **SHOULD** be set to zero. This bit is not used when selecting a MEG SBD-DR, i.e., it **MUST** be ignored by the receiver of an SBD-IMET route.

In the context of a given Tenant Domain, to select the MEG SBD-DR, the MEGs of the Tenant Domain perform the following procedure:

- From the set of received SBD-IMET routes for the given Tenant Domain, determine the candidate set of PEs that support MEG functionality for that domain.
- Select a DF election algorithm as specified in [RFC8584]. Some of the possible algorithms can be found, e.g., in [RFC7432], [RFC8584], and [EVPN-DF].
- Apply the DF election algorithm (see [RFC8584]) to the candidate set of PEs. The winner becomes the MEG SBD-DR.

Note that if a given PE supports IPMG ([Section 6.1.2](#)) or PEG ([Section 6.1.4](#)) functionality as well as MEG functionality, its SBD-IMET routes carry only one DF Election EC.

6.1.3. Interworking with Global Table Multicast

If multicast service to the outside sources and/or receivers is provided via the BGP-based Global Table Multicast (GTM) procedures of [\[RFC7716\]](#), the procedures of [Section 6.1.2](#) can easily be adapted for EVPN/GTM interworking. The way to adapt the MVPN procedures to GTM is explained in [\[RFC7716\]](#).

6.1.4. Interworking with PIM

As discussed, there may be receivers in an EVPN Tenant Domain that are interested in multicast flows whose sources are outside the EVPN Tenant Domain. Or there may be receivers outside an EVPN Tenant Domain that are interested in multicast flows whose sources are inside the Tenant Domain.

If the outside sources and/or receivers are part of an MVPN, see the procedures for interworking that are covered in [Section 6.1.2](#).

There are also cases where an external source or receiver are attached via IP and the Layer 3 multicast routing is done via PIM. In this case, the interworking between the PIM domain and the EVPN Tenant Domain is done at L3 Gateways that perform PIM/EVPN Gateway (PEG) functionality. A PEG is very similar to a MEG, except that its Layer 3 multicast routing is done via PIM rather than via BGP.

If external sources or receivers for a given group are attached to a PEG via a Layer 3 interface, that interface should be treated as a VRF interface attached to the Tenant Domain's L3VPN VRF. The Layer 3 multicast routing instance for that Tenant Domain will either run PIM on the VRF interface or listen for IGMP/MLD messages on that interface. If the external receiver is attached elsewhere on an IP network, the PE has to enable PIM on its interfaces to the backbone network. In both cases, the PE needs to perform PEG functionality, and its IMET routes must carry the Multicast Flags EC with the PEG flag set.

For each BD on which there is a multicast source or receiver, one of the PEGs will become the PEG DR. DR selection can be done using the same procedures specified in [Section 6.1.2.4](#), except with PEG substituted for MEG.

As long as there are no tenant multicast routers within the EVPN Tenant Domain, the PEGs do not need to run PIM on their IRB interfaces.

6.1.4.1. Source Inside EVPN Domain

If a PEG receives a PIM Join (S,G) from outside the EVPN Tenant Domain, it may find it necessary to create (S,G) state. The PE needs to determine whether S is within the Tenant Domain. If S is not within the EVPN Tenant Domain, the PE carries out normal Layer 3 multicast routing procedures. If S is within the EVPN Tenant Domain, the IIF of the (S,G) state is set as follows:

- If S is on a BD that is attached to the PE, the IIF is the PE's IRB interface to that BD.

- If S is not on a BD that is attached to the PE, the IIF is the PE's IRB interface to the SBD.

When the PE creates such an (S,G) state, it **MUST** originate (if it hasn't already) an SBD-SMET route for (S,G). This will cause it to pull the (S,G) traffic via Layer 2. When the traffic arrives over an EVPN tunnel, it gets sent up an IRB interface where the Layer 3 multicast routing determines the packet's disposition. The SBD-SMET route is withdrawn when the (S,G) state no longer exists (unless there is some other reason for not withdrawing it).

If there are no tenant multicast routers within the EVPN Tenant Domain, there cannot be an RP in the Tenant Domain, so a PEG does not have to handle externally arriving PIM Join (*,G) messages.

The PEG DR for a particular BD **MUST** act as the a First Hop Router for that BD. It will examine all (S,G) traffic on the BD, and whenever G is an ASM group, the PEG DR will send Register messages to the RP for G. This means that the PEG DR will need to pull all the (S,G) traffic originating on a given BD by originating a SMET (*,*) route for that BD. If a PEG DR is the DR for all the BDs, it **SHOULD** originate just an SBD-SMET (*,*) route rather than a SMET (*,*) route for each BD.

The rules for exporting IP routes to multicast sources are the same as those specified for MEGs in [Section 6.1.2.2](#), except that the exported routes will be IP routes rather than VPN-IP routes, and it is not necessary to attach the VRF Route Import EC or the Source AS EC.

When a source is on a multihomed segment, the same issue discussed in [Section 6.1.2.3](#) exists. Suppose S is on an Ethernet segment, belonging to BD1, that is multihomed to both PE1 and PE2, where PE1 is a PEG. And suppose that IP multicast traffic from S to G travels over the AC that attaches the segment to PE2. If PE1 receives an external PIM Join (S,G) route, it **MUST** originate a SMET route for (S,G). Normal OISM procedures will cause PE2 to send the (S,G) traffic to PE1 on an EVPN IP multicast tunnel. Normal OISM procedures will also cause PE1 to send the (S,G) traffic up its BD1 IRB interface. Normal PIM procedures will then cause PE1 to forward the traffic along a PIM tree. In this case, the routing is not optimal, but the traffic does flow correctly.

6.1.4.2. Source Outside EVPN Domain

By means of normal OISM procedures, a PEG learns whether there are receivers in the Tenant Domain that are interested in receiving (*,G) or (S,G) traffic. The PEG must determine whether or not S (or the RP for G) is outside the EVPN Tenant Domain. If so, and if there is a receiver on BD1 interested in receiving such traffic, the PEG DR for BD1 is responsible for originating a PIM Join (S,G) or Join (*,G) control message.

An alternative would be to allow any PEG that is directly attached to a receiver to originate the PIM Joins. Then, the PEG DR would only have to originate PIM Joins on behalf of receivers that are not attached to a PEG. However, if this is done, it is necessary for the PEGs to run PIM on all their IRB interfaces so that the PIM Assert procedures can be used to prevent duplicate delivery to a given BD.

The IIF for the Layer 3 (S,G) or (*,G) state is determined by normal PIM procedures. If a receiver is on BD1, and the PEG DR is attached to BD1, its IRB interface to BD1 is added to the OIF list. This ensures that any receivers locally attached to the PEG DR will receive the traffic. If there are

receivers attached to other EVPN PEs, then whenever (S,G) traffic from an external source matches a (*,G) state, the PEG will create (S,G) state. The IIF will be set to whatever external interface the traffic is expected to arrive on (copied from the (*,G) state), the OIF list is copied from the (*,G) state, and the SBD IRB interface is added to the OIF list.

6.2. Interworking with PIM via an External PIM Router

[Section 6.1](#) describes how to use an OISM PE router as the gateway to a non-EVPN multicast domain when the EVPN Tenant Domain is not being used as an intermediate transit network for multicast. An alternative approach is to have one or more external PIM routers (perhaps operated by a tenant) on one of the BDs of the Tenant Domain. We will refer to this BD as the "gateway BD".

In this model:

- The EVPN Tenant Domain is treated as a stub network attached to the external PIM routers.
- The external PIM routers follow normal PIM procedures and provide the FHR and LHR functionality for the entire Tenant Domain.
- The OISM PEs do not run PIM.
- There **MUST NOT** be more than one gateway BD.
- If an OISM PE not attached to the gateway BD has interest in a given multicast flow, it conveys that interest, following normal OISM procedures, by originating an SBD-SMET route for that flow.
- If a PE attached to the gateway BD receives an SBD-SMET, it may need to generate and transmit a corresponding IGMP/MLD Join on one or more of its ACs. (Procedures for generating an IGMP/MLD Join as a result of receiving a SMET route are given in [\[RFC9251\]](#).) The PE **MUST** know which BD is the gateway BD and **MUST NOT** transmit an IGMP/MLD Join to any other BDs. Furthermore, even if a particular AC is part of that BD, the PE **SHOULD NOT** transmit an IGMP/MLD Join on that AC unless there is an external PIM router attached via that AC.

As a result, IGMP/MLD messages will be received by the external PIM routers on the gateway BD, and those external PIM routers will send PIM Join messages externally as required. Traffic for the given multicast flow will then be received by one of the external PIM routers, and that traffic will be forwarded by that router to the gateway BD.

The normal OISM procedures will then cause the given multicast flow to be tunneled to any PEs of the EVPN Tenant Domain that have interest in the flow. PEs attached to the gateway BD will see the flow as originating from the gateway BD, and other PEs will see the flow as originating from the SBD.

- An OISM PE attached to a gateway BD **MUST** set its Layer 2 multicast state to indicate that each AC to the gateway BD has interest in all multicast flows. It **MUST** also originate a SMET route for (*,*). The procedures for originating SMET routes are discussed in [Section 2.5](#).

This will cause the OISM PEs attached to the gateway BD to receive all the IP multicast traffic that is sourced within the EVPN Tenant Domain and to transmit that traffic to the gateway BD, where the external PIM routers will receive it. This enables the external PIM routers to

perform FHR functions on behalf of the entire Tenant Domain. (Of course, if the gateway BD has a multihomed segment, only the PE that is the DF for that segment will transmit the multicast traffic to the segment.)

7. Using an EVPN Tenant Domain as an Intermediate (Transit) Network for Multicast Traffic

In this section, we consider the scenario where one or more BDs of an EVPN Tenant Domain are being used to carry IP multicast traffic for which the source and at least one receiver are not part of the Tenant Domain. That is, one or more BDs of the Tenant Domain are intermediate links of a larger multicast tree created by PIM.

We define a "tenant multicast router" as a multicast router, running PIM, that:

1. is attached to one or more BDs of the Tenant Domain but
2. is not an EVPN PE router.

In order for an EVPN Tenant Domain to be used as a transit network for IP multicast, one or more of its BDs must have tenant multicast routers, and an OISM PE attached to such a BD **MUST** be provisioned to enable PIM on its IRB interface to that BD. (This is true even if none of the tenant routers is on a segment attached to the PE.) Further, all the OISM PEs (even ones not attached to a BD with tenant multicast routers) **MUST** be provisioned to enable PIM on their SBD IRB interfaces.

If PIM is enabled on a particular BD, the DR selection procedure of [Section 6.1.2.4](#) **MUST** be replaced by the normal PIM DR Election procedure of [RFC7761]. Note that this may result in one of the tenant routers being selected as the DR rather than one of the OISM PE routers. In this case, First Hop Router and Last Hop Router functionality will not be performed by any of the EVPN PEs.

A PIM control message on a particular BD is considered to be a link-local multicast message and, as such, is sent transparently from PE to PE via the BUM tunnel for that BD. This is true whether the control message was received from an AC or from the local Layer 3 routing instance via an IRB interface.

A PIM Join/Prune message contains three fields that are relevant to the present discussion:

- Upstream Neighbor
- Group Address (G)
- Source Address (S), omitted in the case of (*,G) Join/Prune messages

We will generally speak of a PIM Join as a Join (S,G) or a Join (*,G) message and will use the term "Join (X,G)" to mean either "Join (S,G)" or "Join (*,G)". In the context of a Join (X,G), we will use the term "X" to mean "S" in the case of (S,G) or "G's RP" in the case of (*,G).

Suppose BD1 contains two tenant multicast routers, say C1 and C2. Suppose C1 is on a segment attached to PE1 and C2 is on a segment attached to PE2. When C1 sends a PIM Join (X,G) to BD1, the Upstream Neighbor field might be set to PE1, PE2, or C2. C1 chooses the Upstream Neighbor based on its unicast routing. Typically, it will choose the PIM router on BD1 that is closest (according to the unicast routing) to X as the Upstream Neighbor. Note that this will not necessarily be PE1. PE1 may not even be visible to the unicast routing algorithm used by the tenant routers. Even if it is, it is unlikely to be the PIM router that is closest to X. So we need to consider the following two cases:

1. C1 sends a PIM Join (X,G) to BD1, with PE1 as the Upstream Neighbor.

PE1's PIM routing instance will receive the Join arrive on the BD1 IRB interface. If X is not within the Tenant Domain, PE1 handles the Join according to normal PIM procedures. This will generally result in PE1 selecting an Upstream Neighbor and sending it a Join (X,G).

If X is within the Tenant Domain but is attached to some other PE, PE1 sends (if it hasn't already) an SBD-SMET route for (X,G). The IIF of the Layer 3 (X,G) state will be the SBD IRB interface, and the OIF list will include the IRB interface to BD1.

The SBD-SMET route will pull the (X,G) traffic to PE1, and the (X,G) state will result in the (X,G) traffic being forwarded to C1.

If X is within the Tenant Domain but is attached to PE1 itself, no SBD-SMET route is sent. The IIF of the Layer 3 (X,G) state will be the IRB interface to X's BD, and the OIF list will include the IRB interface to BD1.

2. C1 sends a PIM Join (X,G) to BD1, with either PE2 or C2 as the Upstream Neighbor.

PE1's PIM routing instance will receive the Join arrive on the BD1 IRB interface. If neither X nor Upstream Neighbor is within the Tenant Domain, PE1 handles the Join according to normal PIM procedures. This will NOT result in PE1 sending a Join (X,G).

If either X or Upstream Neighbor is within the Tenant Domain, PE1 sends (if it hasn't already) an SBD-SMET route for (X,G). The IIF of the Layer 3 (X,G) state will be the SBD IRB interface, and the OIF list will include the IRB interface to BD1.

The SBD-SMET route will pull the (X,G) traffic to PE1, and the (X,G) state will result in the (X,G) traffic being forwarded to C1.

8. IANA Considerations

IANA has assigned new flags in the "Multicast Flags Extended Community" registry under the "Border Gateway Protocol (BGP) Extended Communities" registry as shown below.

Bit	Name	Reference	Change Controller
7	OISM SBD	RFC 9625	IETF
9	IPMG	RFC 9625	IETF
10	MEG	RFC 9625	IETF

Bit	Name	Reference	Change Controller
11	PEG	RFC 9625	IETF
12	OISM-supported	RFC 9625	IETF

Table 1: Multicast Flags Extended Community Registry

9. Security Considerations

This document uses protocols and procedures defined in the normative references and inherits the security considerations of those references.

This document adds flags or Extended Communities (ECs) to a number of BGP routes in order to signal that particular nodes support the OISM, IPMG, MEG, and/or PEG functionalities that are defined in this document. Incorrect addition, removal, or modification of those flags and/or ECs will cause the procedures defined herein to malfunction, in which case loss or diversion of data traffic is possible. Implementations should provide tools to easily debug configuration mistakes that cause the signaling of incorrect information.

The interworking with non-OISM networks described in Sections 5 and 6 requires gateway functions in multiple redundant PEs, among which one of them is elected as Designated Forwarder for a given BD (or SBD). The election of the MEG or PEG DR, as well as the IPMG Designated Forwarder, makes use of the Designated Forwarder election procedures [RFC8584]. An attacker with access to one of these Gateways may influence such election and therefore modify the forwarding of multicast traffic between the OISM network and the external domain. The operator should be especially careful with the protection of these gateways by making sure the management interfaces to access the gateways are only allowed to authorized operators.

The document also introduces the concept of per-Tenant-Domain dissemination for the SMET routes, as opposed to per-BD distribution in [RFC9251]. That is, a SMET route triggered by the reception of an IGMP/MLD Join in BD-1 on PE1 needs to be distributed and imported by all PEs of the Tenant Domain, even to those PEs that are not attached to BD-1. This means that an attacker with access to only one BD in a PE of the Tenant Domain might force the advertisement of SMET routes and impact the resources of all the PEs of the Tenant Domain, as opposed to only the PEs of that particular BD (as in [RFC9251]). The implementation should provide ways to filter/control the client IGMP/MLD reports that are received by the attached hosts.

10. References

10.1. Normative References

- [RFC2119] Bradner, S., "Key words for use in RFCs to Indicate Requirement Levels", BCP 14, RFC 2119, DOI 10.17487/RFC2119, March 1997, <<https://www.rfc-editor.org/info/rfc2119>>.

-
- [RFC3032] Rosen, E., Tappan, D., Fedorkow, G., Rekhter, Y., Farinacci, D., Li, T., and A. Conta, "MPLS Label Stack Encoding", RFC 3032, DOI 10.17487/RFC3032, January 2001, <<https://www.rfc-editor.org/info/rfc3032>>.
- [RFC3376] Cain, B., Deering, S., Kouvelas, I., Fenner, B., and A. Thyagarajan, "Internet Group Management Protocol, Version 3", RFC 3376, DOI 10.17487/RFC3376, October 2002, <<https://www.rfc-editor.org/info/rfc3376>>.
- [RFC3810] Vida, R., Ed. and L. Costa, Ed., "Multicast Listener Discovery Version 2 (MLDv2) for IPv6", RFC 3810, DOI 10.17487/RFC3810, June 2004, <<https://www.rfc-editor.org/info/rfc3810>>.
- [RFC4360] Sangli, S., Tappan, D., and Y. Rekhter, "BGP Extended Communities Attribute", RFC 4360, DOI 10.17487/RFC4360, February 2006, <<https://www.rfc-editor.org/info/rfc4360>>.
- [RFC6625] Rosen, E., Ed., Rekhter, Y., Ed., Hendrickx, W., and R. Qiu, "Wildcard in Multicast VPN Auto-Discovery Routes", RFC 6625, DOI 10.17487/RFC6625, May 2012, <<https://www.rfc-editor.org/info/rfc6625>>.
- [RFC7153] Rosen, E. and Y. Rekhter, "IANA Registries for BGP Extended Communities", RFC 7153, DOI 10.17487/RFC7153, March 2014, <<https://www.rfc-editor.org/info/rfc7153>>.
- [RFC7432] Sajassi, A., Ed., Aggarwal, R., Bitar, N., Isaac, A., Uttaro, J., Drake, J., and W. Henderickx, "BGP MPLS-Based Ethernet VPN", RFC 7432, DOI 10.17487/RFC7432, February 2015, <<https://www.rfc-editor.org/info/rfc7432>>.
- [RFC8174] Leiba, B., "Ambiguity of Uppercase vs Lowercase in RFC 2119 Key Words", BCP 14, RFC 8174, DOI 10.17487/RFC8174, May 2017, <<https://www.rfc-editor.org/info/rfc8174>>.
- [RFC8584] Rabadan, J., Ed., Mohanty, S., Ed., Sajassi, A., Drake, J., Nagaraj, K., and S. Sathappan, "Framework for Ethernet VPN Designated Forwarder Election Extensibility", RFC 8584, DOI 10.17487/RFC8584, April 2019, <<https://www.rfc-editor.org/info/rfc8584>>.
- [RFC9135] Sajassi, A., Salam, S., Thoria, S., Drake, J., and J. Rabadan, "Integrated Routing and Bridging in Ethernet VPN (EVPN)", RFC 9135, DOI 10.17487/RFC9135, October 2021, <<https://www.rfc-editor.org/info/rfc9135>>.
- [RFC9136] Rabadan, J., Ed., Henderickx, W., Drake, J., Lin, W., and A. Sajassi, "IP Prefix Advertisement in Ethernet VPN (EVPN)", RFC 9136, DOI 10.17487/RFC9136, October 2021, <<https://www.rfc-editor.org/info/rfc9136>>.
- [RFC9251] Sajassi, A., Thoria, S., Mishra, M., Patel, K., Drake, J., and W. Lin, "Internet Group Management Protocol (IGMP) and Multicast Listener Discovery (MLD) Proxies for Ethernet VPN (EVPN)", RFC 9251, DOI 10.17487/RFC9251, June 2022, <<https://www.rfc-editor.org/info/rfc9251>>.

- [RFC9572] Zhang, Z., Lin, W., Rabadan, J., Patel, K., and A. Sajassi, "Updates to EVPN Broadcast, Unknown Unicast, or Multicast (BUM) Procedures", RFC 9572, DOI 10.17487/RFC9572, May 2024, <<https://www.rfc-editor.org/info/rfc9572>>.
- [RFC9574] Rabadan, J., Ed., Sathappan, S., Lin, W., Katiyar, M., and A. Sajassi, "Optimized Ingress Replication Solution for Ethernet VPNs (EVPNs)", RFC 9574, DOI 10.17487/RFC9574, May 2024, <<https://www.rfc-editor.org/info/rfc9574>>.

10.2. Informative References

- [EVPN-BUM] Zhang, Z., Przygienda, T., Sajassi, A., and J. Rabadan, "EVPN Broadcast, Unknown Unicast, and Multicast (BUM) Using Bit Index Explicit Replication (BIER)", Work in Progress, Internet-Draft, draft-ietf-bier-evpn-14, August 2024, <<https://datatracker.ietf.org/doc/html/draft-ietf-bier-evpn-14>>.
- [EVPN-DF] Rabadan, J., Sathappan, S., Lin, W., Drake, J., and A. Sajassi, "Preference-based EVPN DF Election", Work in Progress, Internet-Draft, draft-ietf-bess-evpn-pref-df-13, 9 October 2023, <<https://datatracker.ietf.org/doc/html/draft-ietf-bess-evpn-pref-df-13>>.
- [RFC4364] Rosen, E. and Y. Rekhter, "BGP/MPLS IP Virtual Private Networks (VPNs)", RFC 4364, DOI 10.17487/RFC4364, February 2006, <<https://www.rfc-editor.org/info/rfc4364>>.
- [RFC4541] Christensen, M., Kimball, K., and F. Solensky, "Considerations for Internet Group Management Protocol (IGMP) and Multicast Listener Discovery (MLD) Snooping Switches", RFC 4541, DOI 10.17487/RFC4541, May 2006, <<https://www.rfc-editor.org/info/rfc4541>>.
- [RFC6513] Rosen, E., Ed. and R. Aggarwal, Ed., "Multicast in MPLS/BGP IP VPNs", RFC 6513, DOI 10.17487/RFC6513, February 2012, <<https://www.rfc-editor.org/info/rfc6513>>.
- [RFC6514] Aggarwal, R., Rosen, E., Morin, T., and Y. Rekhter, "BGP Encodings and Procedures for Multicast in MPLS/BGP IP VPNs", RFC 6514, DOI 10.17487/RFC6514, February 2012, <<https://www.rfc-editor.org/info/rfc6514>>.
- [RFC7606] Chen, E., Ed., Scudder, J., Ed., Mohapatra, P., and K. Patel, "Revised Error Handling for BGP UPDATE Messages", RFC 7606, DOI 10.17487/RFC7606, August 2015, <<https://www.rfc-editor.org/info/rfc7606>>.
- [RFC7716] Zhang, J., Giuliano, L., Rosen, E., Ed., Subramanian, K., and D. Pacella, "Global Table Multicast with BGP Multicast VPN (BGP-MVPN) Procedures", RFC 7716, DOI 10.17487/RFC7716, December 2015, <<https://www.rfc-editor.org/info/rfc7716>>.

- [RFC7761] Fenner, B., Handley, M., Holbrook, H., Kouvelas, I., Parekh, R., Zhang, Z., and L. Zheng, "Protocol Independent Multicast - Sparse Mode (PIM-SM): Protocol Specification (Revised)", STD 83, RFC 7761, DOI 10.17487/RFC7761, March 2016, <<https://www.rfc-editor.org/info/rfc7761>>.
- [RFC8296] Wijnands, IJ., Ed., Rosen, E., Ed., Dolganow, A., Tantsura, J., Aldrin, S., and I. Meilik, "Encapsulation for Bit Index Explicit Replication (BIER) in MPLS and Non-MPLS Networks", RFC 8296, DOI 10.17487/RFC8296, January 2018, <<https://www.rfc-editor.org/info/rfc8296>>.

Appendix A. Integrated Routing and Bridging

This appendix provides a short tutorial on the interaction of routing and bridging. First, it shows the traditional model, where bridging and routing are performed in separate devices. Then, it shows the model specified in [RFC9135], where a single device contains both routing and bridging functions. The latter model is presupposed in the body of this document.

Figure 2 shows a traditional router that only does routing and has no L2 bridging capabilities. There are two LANs: LAN1 and LAN2. LAN1 is realized by switch1, and LAN2 is realized by switch2. The router has an interface, lan1, that attaches to LAN1 (via switch1) and an interface, lan2, that attaches to LAN2 (via switch2). Each interface is configured, as an IP interface, with an IP address and a subnet mask.

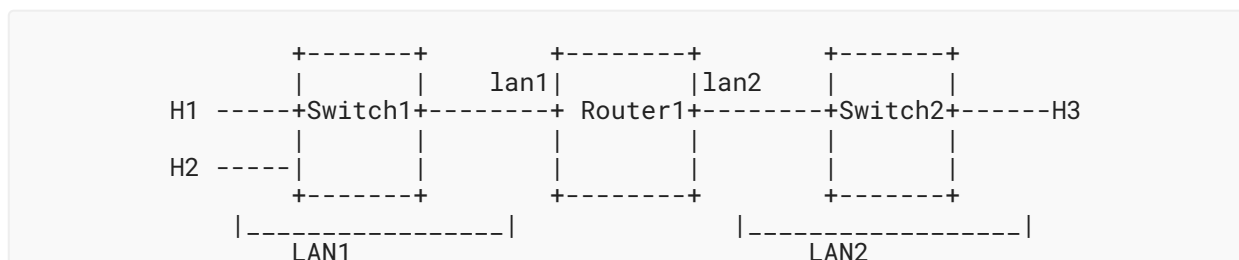

Figure 2: Conventional Router with LAN Interfaces

IP traffic (unicast or multicast) that remains within a single subnet never reaches the router. For instance, if H1 emits an Ethernet frame with H2's MAC address in the Ethernet Destination Address field, the frame will go from H1 to Switch1 to H2 without ever reaching the router. Since the frame is never seen by a router, the IP datagram within the frame remains entirely unchanged, e.g., its TTL is not decremented. The Ethernet Source and Destination MAC addresses are not changed either.

If H1 wants to send a unicast IP datagram to H3, which is on a different subnet, H1 has to be configured with the IP address of a default router. Let's assume that H1 is configured with an IP address of Router1 as its default router address. H1 compares H3's IP address with its own IP address and IP subnet mask and determines that H3 is on a different subnet. So the packet has to be routed. H1 uses ARP to map Router1's IP address to a MAC address on LAN1. H1 then encapsulates the datagram in an Ethernet frame, using Router1's MAC address as the destination MAC address, and sends the frame to Router1.

In [Figure 3](#), a single device consists of one or more L3 Routing Instances. The routing/forwarding tables of a given routing instance is known as an IP-VRF [[RFC9135](#)]. In the context of EVPN, it is convenient to think of each routing instance as representing the routing of a particular tenant. Each IP-VRF is attached to one or more interfaces.

When several EVPN PEs have a routing instance of the same Tenant Domain, those PEs advertise IP routes to the attached hosts. This is done as specified in [[RFC9135](#)].

The integrated router/bridge shown in [Figure 3](#) also attaches to a number of Broadcast Domains (BDs). Each BD performs the functions that are performed by the bridges in [Figure 2](#). To the L3 routing instance, each BD appears to be a LAN. The interface attaching a particular BD to a particular IP-VRF is known as an "IRB interface". From the perspective of L3 routing, each BD is a subnet. Thus, each IRB interface is configured with a MAC address (which is the router's MAC address on the corresponding LAN), as well as an IP address and subnet mask.

The integrated router/bridge shown in [Figure 3](#) may have multiple ACs to each BD. These ACs are visible only to the bridging function, not to the routing instance. To the L3 routing instance, there is just one interface to each BD.

If the L3 routing instance represents the IP routing of a particular tenant, the BDs attached to that routing instance are BDs belonging to that same tenant.

Bridging and routing now proceed exactly as in the case of [Figure 2](#), except that BD1 replaces Switch1, BD2 replaces Switch2, interface IRB1 replaces interface lan1, and interface IRB2 replaces interface lan2.

It is important to understand that an IRB interface connects an L3 routing instance to a BD, NOT to a MAC-VRF (see [[RFC7432](#)] for the definition of MAC-VRF). A MAC-VRF may contain several BDs, as long as no MAC address appears in more than one BD. From the perspective of the L3 routing instance, each individual BD is an individual IP subnet; whether or not each BD has its own MAC-VRF is irrelevant to the L3 routing instance.

[Figure 4](#) illustrates IRB when a pair of BDs (subnets) are attached to two different PE routers. In this example, each BD has two segments, and one segment of each BD is attached to one PE router.

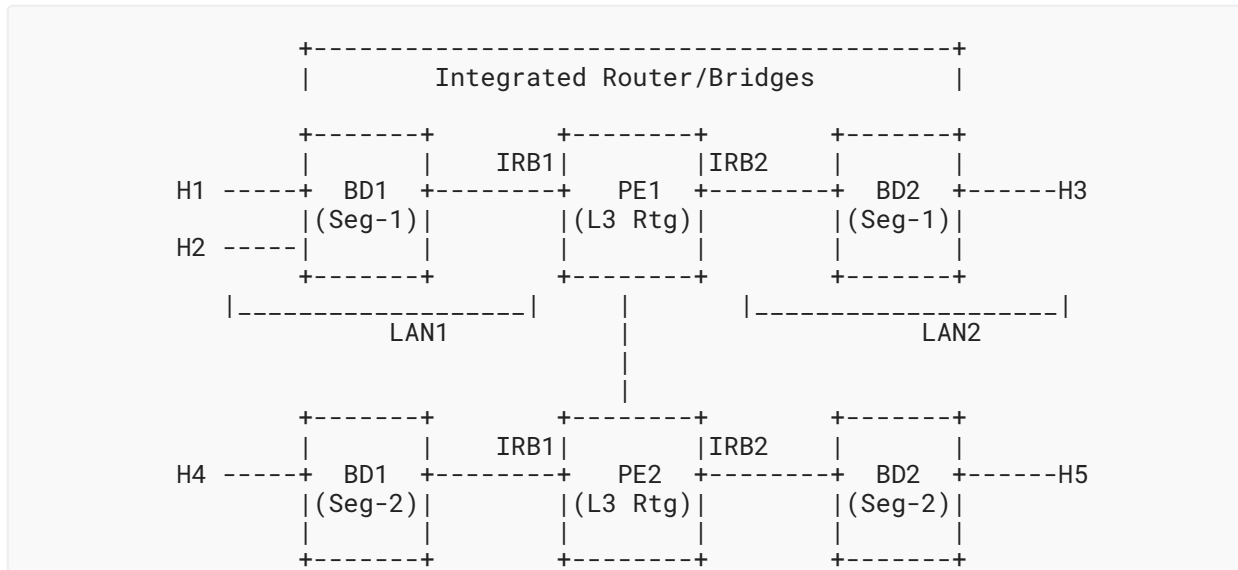

Figure 4: Integrated Router/Bridges with Distributed Subnet

If H1 needs to send an IP packet to H4, it determines from its IP address and subnet mask that H4 is on the same subnet as H1. Although H1 and H4 are not attached to the same PE router, EVPN provides Ethernet communication among all hosts that are on the same BD. Thus, H1 uses ARP to find H4's MAC address and sends an Ethernet frame with H4's MAC address in the Destination MAC Address field. The frame is received at PE1, but since the Destination MAC address is not PE1's MAC address, PE1 assumes that the frame is to remain on BD1. Therefore, the packet inside the frame is NOT decapsulated and is NOT sent up the IRB interface to PE1's routing instance. Rather, standard EVPN intra-subnet procedures (as detailed in [RFC7432]) are used to deliver the frame to PE2, which then sends it to H4.

If H1 needs to send an IP packet to H5, it determines from its IP address and subnet mask that H5 is NOT on the same subnet as H1. Assuming that H1 has been configured with the IP address of PE1 as its default router, H1 sends the packet in an Ethernet frame with PE1's MAC address in its Destination MAC Address field. PE1 receives the frame and sees that the frame is addressed to it. Thus, PE1 sends the frame up its IRB1 interface to the L3 routing instance. Appropriate IP processing is done, e.g., TTL decrement. The L3 routing instance determines that the next hop for H5 is PE2, so the packet is encapsulated (e.g., in MPLS) and sent across the backbone to PE2's routing instance. PE2 will see that the packet's destination, H5, is on BD2 segment-2 and will send the packet down its IRB2 interface. This causes the IP packet to be encapsulated in an Ethernet frame with PE2's MAC address (on BD2) in the Source Address field and H5's MAC address in the Destination Address field.

Note that if H1 has an IP packet to send to H3, the forwarding of the packet is handled entirely within PE1. PE1's routing instance sees the packet arrive on its IRB1 interface and then transmits the packet by sending it down its IRB2 interface.

Often, all the hosts in a particular Tenant Domain will be provisioned with the same value of the default router IP address. This IP address can be provisioned as an anycast address in all the EVPN PEs attached to that Tenant Domain. Thus, although all hosts are provisioned with the same default router address, the actual default router for a given host will be one of the PEs attached to the same Ethernet segment as the host. This provisioning method ensures that IP packets from a given host are handled by the closest EVPN PE that supports IRB.

In the topology of [Figure 4](#), one could imagine that H1 is configured with a default router address that belongs to PE2 but not to PE1. Inter-subnet routing would still work, but IP packets from H1 to H3 would then follow the non-optimal path H1-->PE1-->PE2-->PE1-->H3. Sending traffic on this sort of path, where it leaves a router and then comes back to the same router, is sometimes known as "hairpinning". Similarly, if PE2 supports IRB but PE1 does not, the same non-optimal path from H1 to H3 would have to be followed. To avoid hairpinning, each EVPN PE needs to support IRB.

It is worth pointing out the way IRB interfaces interact with multicast traffic. Referring again to [Figure 4](#), suppose PE1 and PE2 are functioning as IP multicast routers. Also, suppose that H3 transmits a multicast packet and both H1 and H4 are interested in receiving that packet. PE1 will receive the packet from H3 via its IRB2 interface. The Ethernet encapsulation from BD2 is removed, the IP header processing is done, and the packet is then re-encapsulated for BD1, with PE1's MAC address in the MAC Source Address field. Then, the packet is sent down the IRB1 interface. Layer 2 procedures (as defined in [\[RFC7432\]](#)) would then be used to deliver a copy of the packet locally to H1 and remotely to H4.

Please be aware that this document modifies the semantics, described in the previous paragraph, of sending/receiving multicast traffic on an IRB interface. This is explained in [Section 1.5.1](#) and subsequent sections.

Acknowledgements

The authors thank Vikram Nagarajan and Princy Elizabeth for their work on [Sections 6.2](#) and [3.2.3.1](#). The authors also benefited tremendously from discussions with Aldrin Isaac on EVPN multicast optimizations.

Authors' Addresses

Wen Lin

Juniper Networks, Inc.
10 Technology Park Drive
Westford, MA 01886
United States of America
Email: wlin@juniper.net

Zhaohui Zhang

Juniper Networks, Inc.
10 Technology Park Drive
Westford, MA 01886
United States of America
Email: zzhang@juniper.net

John Drake

Juniper Networks, Inc.
1194 N. Mathilda Ave
Sunnyvale, CA 94089
United States of America
Email: jdrake@juniper.net

Eric C. Rosen (EDITOR)

Juniper Networks, Inc.
10 Technology Park Drive
Westford, MA 01886
United States of America
Email: erosen52@gmail.com

Jorge Rabadan

Nokia
777 E. Middlefield Road
Mountain View, CA 94043
United States of America
Email: jorge.rabadan@nokia.com

Ali Sajassi

Cisco Systems
170 West Tasman Drive
San Jose, CA 95134
United States of America
Email: sajassi@cisco.com